

# **JEMENA NETWORK OPERATOR RULES (NOR)**

**GAS SUPPLY ACT 1996 (NSW)**

**GAS SUPPLY (SAFETY AND NETWORK MANAGEMENT)  
REGULATION 2013 (NSW)**

Issue Date: 01/01/2020

**CALL 131 909 FOR GAS EMERGENCY**

**PUBLIC**

© Jemena Limited. All rights reserved. Copyright in the whole or every part of this document belongs to Jemena Limited, and cannot be used, transferred, copied or reproduced in whole or in part in any manner or form or in any media to any person other than with the prior written consent of Jemena.

Printed or downloaded copies of this document are deemed uncontrolled



## DOCUMENT HISTORY

Issue Date	Amended by	Description of Changes
November 2011	J Commarmond	Various changes to align with Gas Supply Amendment Regulation 2010.
January 2018	J Chang	Revised into new format. Various changes throughout to all sections reflecting the current technical and regulatory requirements.
January 2020	T Bodsworth	Various amendments throughout to all sections reflecting company policy changes.

## AUTHORISATION

### REVIEWED BY

Name	Job Title	Signature	Date
John Martin	Engineering Support Manager – Gas Distribution		13/12/2019

### Approved by

Name	Job Title	Signature	Date
Peter Harcus	GM Asset Management – Gas Distribution		13/12/19

## OWNING FUNCTIONAL GROUP & DEPARTMENT / TEAM

Asset Management Asset Management : Asset Strategy Gas : Asset Management Networks

# PART 1: OVERVIEW AND GENERAL REQUIREMENTS

## TABLE OF CONTENTS

1	NETWORK OPERATOR RULES.....	5
1.1	SCOPE .....	5
1.2	PREVIOUS RULES .....	5
1.3	WHO THESE RULES APPLY TO .....	6
1.4	GASFITTING WORK .....	6
1.5	STANDARDS .....	6
1.6	WHAT THE RULES DO NOT COVER.....	7
1.7	CONTACT DETAILS .....	7
1.8	DEFINITIONS .....	8
1.9	DISCLAIMER.....	11
2	PERFORMING GASFITTING WORK.....	12
2.1	CRITERIA FOR PERFORMING GASFITTING WORK .....	12
2.2	RESPONSIBILITIES OF A LICENCED PERSON.....	12
3	COMPLETION OF GASFITTING WORK .....	14
3.1	LEAK TEST CERTIFICATE.....	14
3.2	CERTIFICATE OF COMPLIANCE .....	14
3.3	CORRECTION OF DEFECTIVE WORK .....	15
3.4	NON-COMPLIANCE WITH THESE NETWORK OPERATOR RULES.....	15

# 1 NETWORK OPERATOR RULES

## 1.1 SCOPE

These **Rules** are issued by **Jemena** and form part of **Jemena's Safety and Operating Plan** for its **Networks** in New South Wales. The *Safety and Operating Plan* and these **Rules** are prepared in accordance with the **Gas Supply Regulation**.

These Rules specify **Jemena's** requirements for work involving:

- (a) The installation, alteration, extension or repair of, or any other work on a **consumer service**; and
- (b) The installation or replacement of a gas meter or any part of the **basic metering equipment**.

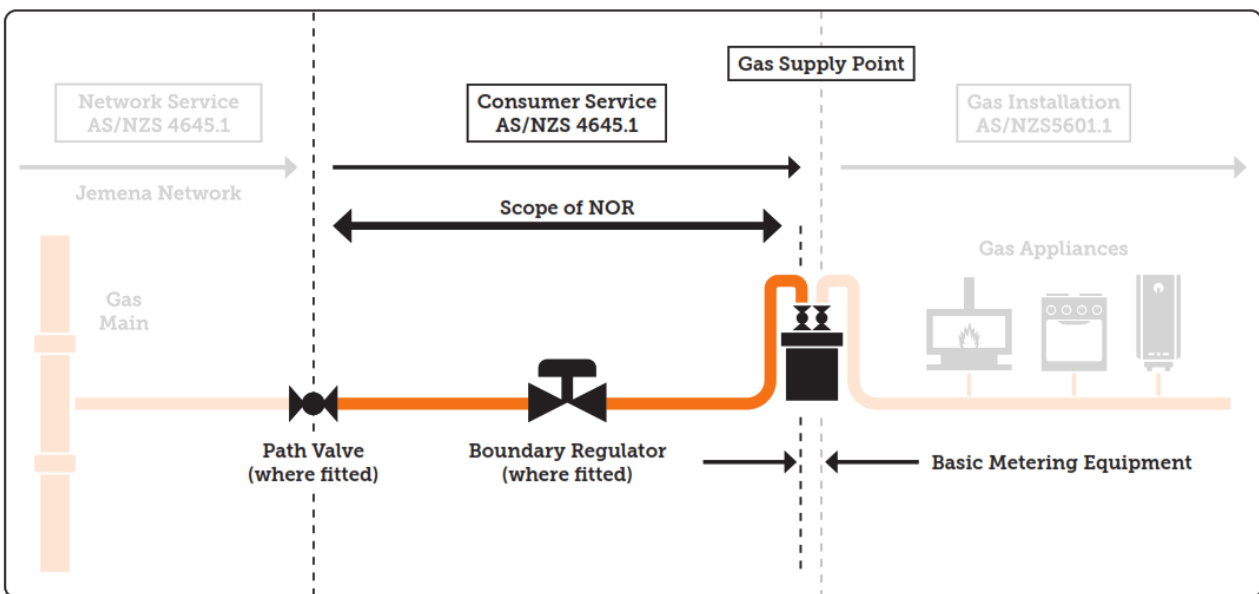

**Figure 1: Infrastructure covered by the scope of these Rules**

The **Rules** are limited to gas pressure (system **MAOP**) up to 400kPa only. For any works on **consumer services** with pressures greater than 400kPa, **Jemena** needs to be contacted directly (see *Section 1.7 – Contact Details*).

## 1.2 PREVIOUS RULES

These **Rules** will apply from 1 January 2020 and replace **Jemena's** previous Network Operator Rules (dated March 2018).

The new design requirements introduced by these **Rules** are not retrospective for existing premises. However, other elements within these **Rules** may apply to existing premises under certain conditions. If further clarification is required, please contact **Jemena** (see *Section 1.7 – Contact Details*).

Note: **Jemena** understands that as of 1 January 2020 some projects will have already passed milestones where it is impracticable to implement some of the new requirements in these **Rules**. Therefore, for projects already in progress, these **Rules** will only apply to new developments having a Development Application lodgement date on or after 1 March 2020 or as formally approved by **Jemena**.

## 1.3 WHO THESE RULES APPLY TO

---

These **Rules** apply to any person who performs **gasfitting work** (as described in *Section 1.8 - Definitions*) associated with a property which is connected or being connected to, or being disconnected from, the **Jemena network**.

Note: Where the person performing the **gasfitting work** is not doing so on behalf of **Jemena** (e.g. where the person is engaged by a gas **consumer** or a **gas retailer**), special additional requirements apply. These are described in *Section 2 – Performing Gasfitting Work*.

## 1.4 GASFITTING WORK

---

The prime objective of these **Rules** is to provide the design and installation requirements for connection of natural gas to a property from the **network**.

The **Rules** specify the requirements for:

- (a) The criteria for a **licenced person** performing **gasfitting work**;
- (b) Process of performing **gasfitting work**; and
- (c) Completing tests after performing **gasfitting work**.

**Gasfitting work** to which these **Rules** apply is defined in *Section 1.8 - Definitions*.

The **Rules** provide for:

- (a) The standards, codes, specifications, methods and procedures to be applied when installing, altering, extending or repairing a **consumer service**;
- (b) The standards, codes, specifications, methods and procedures and requirements for installing or repairing **basic metering equipment**; and
- (c) The requirements for leak test certificates and certificates of compliance.

Compliance with these **Rules**, as well as the codes and standards referred to, is a legislative requirement pursuant to the **Gas Supply Regulation**. The person performing the **gasfitting work** is responsible for having a thorough knowledge and understanding of these regulations.

A person who supervises others performing **gasfitting work** must also accept responsibility for issuing advice and instructions about correct procedures to those performing **gasfitting work** under their supervision and control.

In the event that, for a particular job, there is a need to deviate from the requirements of these **Rules**, **Jemena's** approval for variance must be obtained at the design stage for the job (see *Section 1.7 - Contact Details*).

## 1.5 STANDARDS

---

The following National Standards have been used in the development of these **Rules**.

ASME/ANSI B16.5 - Pipe Flanges and Flanged Fittings;

AS/NZS1170.1 - Structural design actions - Permanent, imposed and other actions;

AS/NZS 1319 – Safety signs for the occupational environment;

AS 1432 - Copper tubes for plumbing, gasfitting and drainage applications;

AS 1725.1 - Chain link fabric fencing - Security fences and gates - General requirements;

AS 2944.1 - Plastics pipes and fittings for gas reticulation - Polyamide pipes;  
AS 3688 – Water supply – metallic fittings and end connectors;  
AS ISO 7.1 – Pipe threads where pressure-tight joints are made on the threads Part 1: Dimensions, tolerances and designation;  
AS/NZS 3000 - Electrical installations;  
AS/NZS 4129 - Fittings for polyethylene (PE) pipes for pressure applications;  
AS/NZS 4130 - Polyethylene (PE) pipes for pressure applications;  
AS/NZS 4645.1 - Gas Distribution Networks (Network Management);  
AS/NZS 4645.2 - Gas Distribution Networks (Steel Pipe Systems);  
AS/NZS 4645.3 - Gas Distribution Networks (Plastic Pipe Systems);  
AS/NZS 60079.10.1 - Explosive atmospheres - Classification of areas - Explosive gas atmospheres;  
and  
AS/NZS 60079.14 - Explosive atmospheres Electrical installations design, selection, erection and initial inspection.

## 1.6 WHAT THE RULES DO NOT COVER

---

Work on the **gas installation** (i.e., downstream of the **basic metering equipment**) is not within the scope of these Rules. The requirements for this work can be found in the *Gas Supply (Consumer Safety) Regulation 2012* and *AS/NZS 5601.1 – Gas Installations (General Installations)*.

This document also does not cover the process for Type B appliance approval. However, **Jemena** reserves the right to withhold gas supply to an installation that does not have Type B appliance approval.

Furthermore, safety requirements for carrying out **gasfitting work** are not within the scope of these **Rules**. It is the responsibility of persons carrying out **gasfitting work** to satisfy themselves as to the particular safety requirements applicable to the work being carried out.

## 1.7 CONTACT DETAILS

---

**Jemena's** contact details are as follow:

Gas Portal Website	<a href="http://mygasservices.jemena.com.au">mygasservices.jemena.com.au</a>
Phone for <b>Jemena</b> Meter Centre:	1300 722 914
Phone for <b>Standby</b> :	1300 665 380
Phone for Customer Service:	1300 137 078
Complaints E-mail Address:	<a href="mailto:CustomerRelationsNSW@jemena.com.au">CustomerRelationsNSW@jemena.com.au</a>
Technical Enquires:	<a href="mailto:Networkoperatorrules@jemena.com.au">Networkoperatorrules@jemena.com.au</a>
E-mail Certificate of Compliance:	<a href="mailto:NG-Compliance@jemena.com.au">NG-Compliance@jemena.com.au</a>
Post:	Attention: Jemena PO Box 1220 North Sydney NSW 2059

## 1.8 DEFINITIONS

The following definitions apply within this document:

<b>ABLOY</b>	Security key locking system utilised by <b>Jemena</b> to secure <b>basic metering equipment</b> . The security code for <b>Jemena</b> padlocks/door locks is A4J.
<b>ASME/ANSI</b>	When followed by numbers or letters <b>ASME/ANSI</b> means a standard published by American Society of Mechanical Engineers/American National Standards Institute, e.g., ASME/ANSI B16.5 – Pipe Flanges and Pipe Fittings.
<b>AS/NZS</b>	When followed by numbers or letters <b>AS/NZS</b> means a standard published by Standards Australia/New Zealand, e.g., AS/NZS 4645.1 - Gas Distribution Networks (Network Management).
<b>Basic metering equipment</b> <i>As defined in Gas Supply (Safety and Network Management) Regulation 2013.- Clause 4</i>	Equipment encompassed in a <b>boundary regulator, meter kit or meter set</b> that includes one or more of the following devices: <ul style="list-style-type: none"> <li>(a) Meters to measure the volume of gas flow;</li> <li>(b) Valves to isolate gas supply;</li> <li>(c) Pipework – including a combination of pipes, flanges, tees, elbows and other pipe connecting equipment designed to convey gas;</li> <li>(d) Fittings – smaller components used in conjunction with fittings, pressure sensing tubing and tube fittings, instrument valves and associated equipment;</li> <li>(e) Filters – devices designed to trap and remove foreign matter from gas streams;</li> <li>(f) Pressure regulators - devices to reduce and control <b>gas pressure</b>;</li> <li>(g) Over pressure protection devices to protect downstream equipment from exposure to excessive pressure (over pressure) in the event of upstream equipment failure;</li> <li>(h) Non-return valves to ensure gas flow travels in one direction and to prevent reverse flow;</li> <li>(i) Mechanical indexes to indicate raw metered gas consumption;</li> <li>(j) Meter bars and other equipment designed to support a gas meter and associated equipment that form part of the meter installation;</li> <li>(k) Electrical connections and wiring to convey electrical signals for gas meters, flow correctors, alarms and metering communications equipment;</li> <li>(l) Flow correction devices or software to enable (actual) uncorrected raw metering data to be adjusted for effects of temperature and/or pressure and/or gas quality and referenced to standard pressure and temperature conditions;</li> <li>(m) Temperature and pressure correction devices or software to enable raw (actual) uncorrected metering data to be adjusted for effects of temperature and pressure; and</li> <li>(n) Devices and equipment designed to analyse and calculate the heating value of the gas stream such as gas chromatographs or calorimeters.</li> </ul>
<b>Boundary regulator</b>	Equipment installed to reduce <b>gas pressure</b> to a lower level prior to entry to high rise buildings, shopping centres and where required for other <b>consumers</b> . (see <b>basic metering equipment</b> for more information).
<b>Consumer</b>	A person who occupies premises connected to a gas network, who is supplied with natural gas by a <b>gas retailer</b> .



<b>Consumer piping</b>	Pipe, fittings, components and other equipment that are owned by the owner of the premises occupied by the <b>consumer</b> . <b>Consumer piping</b> conveys gas to the <b>consumer's</b> appliances from the downstream outlet of the <b>basic metering equipment</b> .
<b>Consumer service</b>	The pipework and associated fittings that conveys gas from the <b>network service</b> to the inlet of the <b>basic metering equipment</b> . If a <b>boundary regulator</b> is installed, the pipework between the <b>boundary regulator</b> and the inlet of the <b>meter kit</b> or <b>meter set</b> is also considered as part of the <b>consumer service</b> .
<b>Embedded Network Provider (ENP)</b>	<b>ENP's</b> operate downstream of a <b>Jemena</b> Boundary Gas meter and usually install individual private meters for consumer billing purposes
<b>Enclosure</b>	Any cage/structure/room where <b>basic metering equipment</b> is housed, with or without a roof.
<b>Gas installation</b>	Installation of <b>consumer piping</b> within a <b>consumer's</b> premises, downstream, of the <b>basic metering equipment</b> .
<b>Gas main</b>	Pipes used in <b>Jemena's network</b> to transport gas.
<b>Gas pressure</b>	The pressure of gas above atmospheric pressure, classified as follows:  (a) Low pressure – up to 7 kPa  (b) Medium Pressure – over 7 kPa and up to 400 kPa  (c) Secondary pressure – over 400 kPa and up to 1050 kPa
<b>Gas retailer</b>	A holder of a <i>retailer authorisation</i> and who supplies natural gas to <b>consumers</b> connected to the <b>network</b> .
<b>Gas Supply Regulation</b>	The <i>Gas Supply (Safety and Network Management) Regulation 2013</i> (NSW), as amended or replaced from time to time.
<b>Gasfitting work</b>	(a) The installation, alteration, extension or repair of any part of a <b>consumer service</b> up to the inlet of the <b>basic metering equipment</b> .  (b) The installation or replacement of a gas meter or any part of the <b>basic metering equipment</b> including <b>boundary regulators</b> .
<b>ISO</b>	When followed by numbers or letters <b>ISO</b> means a standard published by the International Organisation for Standardisation, e.g., ISO 7.1 – Pipe threads where pressure-tight joints are made on the threads Dimensions, tolerances and designation.
<b>Jemena</b>	Jemena Gas Networks (NSW) Limited ACN 003 004 322, being the network owner and operator of the <b>Network</b> .
<b>Licensed person</b>	A person holding a current gasfitters licence issued under the <i>Home Building Act 1989</i> (NSW).
<b>Manual shut-off valve</b>	A manually operated valve which allows a section of pipework to be shut off.
<b>Master isolation valve</b>	A valve installed to isolate gas supply at the point of entry outside the building.

<b>Master meter</b> <i>(non-billable check meter)</i>	A component of the <b>basic metering equipment</b> that is typically used to measure gas flow to water heating systems on high rise buildings with centralised hot water and individual hot water meters. It can apply to other installation types such as commercial tenancies.
<b>Meter set</b>	<b>Basic metering equipment</b> that has been assembled for the purpose of measuring gas flow that exceeds 75 sm <sup>3</sup> /hr.
<b>Meter kit</b>	<b>Basic metering equipment</b> with the purpose of measuring gas flow that is equal to or less than 75 sm <sup>3</sup> /hr.
<b>Meter control valve (MCV)</b>	Isolation valve on the inlet of <b>basic metering equipment</b> .
<b>MAOP</b>	Maximum allowable operating pressure.
<b>Network</b>	<b>Jemena's</b> gas distribution system in New South Wales, consisting of a system of pipes and associated facilities and equipment that are used to convey and control the flow of gas to <b>consumers</b> .  For clarity, the <b>Network</b> : <ul style="list-style-type: none"> <li>(a) Includes any pipe or fitting upstream of the <b>consumer service</b>, generally at a point in the public thoroughfare 225 mm outside the <b>property boundary</b>; and</li> <li>(b) Ends at the downstream outlet of the <b>network service</b>.</li> </ul> Note: The <b>consumer service</b> , including any pipe and associated fittings downstream from the point in the public thoroughfare 225 mm outside the <b>property boundary</b> , is not part of the <b>network</b> .
<b>Network operator</b>	The holder of a <i>Reticulator's Authorisation</i> . For the purpose of these <b>Rules</b> , <b>Jemena</b> is the <b>network operator</b> .
<b>Network service</b>	The part of the <b>network</b> that joins the <b>consumer service</b> .
<b>Property boundary</b>	Is the boundary line which divides private property from public areas, such as public footpaths, streets, roads, public lanes etc.
<b>Path valve</b>	A valve situated approximately 225 mm outside the <b>property boundary</b> at the inlet of the <b>consumer service</b> . It is usually below ground in a path box for easy access, and is used to control the flow of gas into the <b>consumer service</b> .
<b>Rules</b>	These Network Operator Rules (NOR) for the <b>network</b> , as may be amended from time to time.
<b>Ignition Source/ Source of Ignition</b>	Process or event capable of generating sufficient heat to reach the ignition temperature of natural gas in the presence of air; approximately 550 – 600°C
<b>Standby</b>	Means a <b>Jemena</b> representative requested by a <b>licenced person</b> to disconnect or reconnect a service, usually under live gas conditions, while work is in progress.
<b>Type A Appliance</b>	An appliance for which a certification scheme exists
<b>Type B Appliance</b>	An appliance, with a gas consumption in excess of 10MJ/h, for which a certification scheme does not exist
<b>Type 1 enclosure</b>	A type of <b>enclosure</b> that is externally positioned outside the confines of a building. The <b>enclosure</b> is typically constructed of wire fencing, brick or concrete and is not covered by a solid roof.

<b>Type 2 enclosure</b>	A type of internal <b>enclosure</b> that is inside a building. The room may be located at ground level or one level below ground. The room must be sealed (airtight) from the remainder of the building.
-------------------------	--

## 1.9 DISCLAIMER

---

These **Rules** apply to the **consumer service** and **basic metering equipment** including **boundary regulators** associated with **Jemena's network**, specifically in relation to the matters outlined in clause 8(1) of the **Gas Supply Regulation** only. **Jemena** accepts no responsibility for any other use of these **Rules**.

## 2 PERFORMING GASFITTING WORK

### 2.1 CRITERIA FOR PERFORMING GASFITTING WORK

---

A person planning to perform **gasfitting work** must meet **Jemena's** criteria before performing such work.

The person undertaking the **gasfitting work** must:

- (a) Be a **licenced person** in accordance with Fair Trading NSW requirements; and
- (b) Possess the relevant skills or engage suitably qualified personnel with the necessary skills, certifications and competence to undertake **gasfitting work**.

A **licenced person** is deemed to be authorised to install, repair and extend a **consumer service**. This authorisation does not extend to removal of meters without **Jemena's** approval.

Note: the licence details of the person undertaking the **gasfitting work** must be provided as part of an application for gas connection. Application for gas connections are performed by the customer, **licenced person** or customers' **gas retailer** through the gas portal. Refer to *Section 1.7 - Contact Details* for the link to the gas portal.

The verification of the person undertaking the **gasfitting work** is conducted by **Jemena** or its authorised contractor when the meter is being issued for installation. Where **gasfitting work** is undertaken on an existing installation, **Jemena** or its authorised contractor will seek to verify that the above requirements have been met.

### 2.2 RESPONSIBILITIES OF A LICENCED PERSON

---

It is a requirement of these **Rules** that the **licenced person** is fully responsible and liable for all **gasfitting work** they perform, including but not limited to the following:

- (a) Meeting the criteria for performing **gasfitting work** as per *Section 2.1 – Criteria for Performing Gasfitting Work*;
- (b) Once all the criteria are met, performing and / or supervising the **gasfitting work**. If the **licenced person** is supervising the **gasfitting work**, that work must be performed by:
  - i. a licenced and competent gasfitter; and/or
  - ii. an apprentice gasfitter
- (c) Ensuring that the **gasfitting work** complies with the current version of *AS/NZS 4645.1 - Gas Distribution Networks (Network Management)* and any other applicable Australian Standards and these **Rules**;
- (d) Ensuring all work is performed, and all notifications and certificates are provided in accordance with the **Gas Supply Regulation** and these **Rules**;
- (e) Designing and performing the **gasfitting work** in a tradesperson-like manner and to the requirements of **Jemena**;
- (f) If any issues or defects are detected, rectifying those promptly;
- (g) Ensuring when **consumer service** pipes are completely or partially renewed that such pipes are properly connected to the **network service** pipes. Where the supply from the **network**

**service** pipe is defective, do not connect the **consumer service** and notify **Jemena** immediately (see *Section 1.7 - Contact Details*);

- (h) Taking corrective action where a **consumer service** or **basic metering equipment** has been found to be unsafe and to ensure the **consumer** and **Jemena** are advised immediately of the defect and the corrective action taken, as required by regulations governing the issue of leak test certificates;
- (i) Responding to and managing any direct or indirect claims arising from any injury or damage to persons or property through work performed by the **licenced person**, under the **licenced person's** supervision and/or by the **licenced person's** employees or contractors;
- (j) Returning meters or other equipment owned by **Jemena** from premises that have been disconnected by, or under the supervision of, the **licenced person**. Refer to *Part 3 Section 6.16 – Returning a Gas Meter* for more details;
- (k) Ensuring that the **consumer service** is designed and installed so that all gas conveyed through the **consumer service** is measured through the **basic metering equipment**;
- (l) Not tampering with any seals on metering assets or adjusting any regulator or over pressure protection setting unless requested to do so by **Jemena**; and
- (m) Installing **basic metering equipment** in accordance with **Jemena's** installation instructions provided with the equipment.

## 3 COMPLETION OF GASFITTING WORK

### 3.1 LEAK TEST CERTIFICATE

---

Immediately before the **licensed person** performing any **gasfitting work** completes the work, that **licensed person** must conduct a leak test in accordance with *Clause 8 (4) of the Gas Supply Regulation* and *Part 2 Sections 5.10 – Leak Testing the Consumer Service* and *5.11 - Pipework and Components not subjected to the Leak Test* of these **Rules**.

For a new **consumer service**, **Jemena** requires that the leak test certificate be provided before **Jemena** will install the **network service** and connect to the **consumer service**.

If the leak test demonstrates the **gasfitting work** is safe to connect to the **network**, then the **licensed person** must:

- (a) Complete a leak test certificate which specifies that the **gasfitting work** has been tested and the gas supply to the premises has been established or re-established or is ready to be established or re-established; and
- (b) Provide that leak test certificate to **Jemena** and the **consumer** within seven (7) days after the test is conducted.

If the leak test demonstrates that the **gasfitting work** is unsafe to connect to the gas network, then the **licensed person** should correct the fault and submit a completed leak test certificate as above.

If the installation can not be made safe the **licensed person** must:

- (c) Complete a leak test certificate which specifies that the **gasfitting work** is defective and unsafe to connect to the **network**, and
- (d) Provide that leak test certificate to **Jemena** and the **consumer** as soon as practicable after the test is conducted.

The person who performs the test must keep a copy of the leak test certificate for five (5) years from the date on which it was issued.

Jemena's Leak Test Certificate form may be downloaded from <https://jemena.com.au/about/document-centre/gas/network-operator-rules>.

### 3.2 CERTIFICATE OF COMPLIANCE

---

**Jemena** requires a certificate of compliance be provided before **Jemena** will issue a meter and/or regulator for new, modified or upgraded **consumer piping**.

The **licensed person** must issue a certificate of compliance with respect to that **gas installation** to:

- (a) **Jemena**;
- (b) The owner of the installation or a person having the control or management of the installation, and
- (c) NSW Fair Trading,

as required by clause 26 of the *Gas Supply (Consumer Safety) Regulation 2012*.

A copy of the certificate of compliance must be provided by the **licensed person** to **Jemena** within five (5) working days after the **gas installation** is completed.

The **licensed person** who issues the certificate must keep a copy of the certificate of compliance for five (5) years from the date on which it was issued.

Fair Trading NSW's Certificate of Compliance may be downloaded from

<https://www.fairtrading.nsw.gov.au/trades-and-businesses/construction-and-trade-essentials/gasfitters/gas-compliance-requirements>

### 3.3 CORRECTION OF DEFECTIVE WORK

---

At the request of **Jemena**, a **licensed person** must:

- (a) Correct any defects in any **gasfitting work** for which that **licensed person** is responsible,
- (b) Carry out these corrections without undue delay; and
- (c) Promptly issue certificates in respect of such work as required under *Sections 3.1 – Leak Test Certificate* and *3.2 – Certificate of Compliance*.

### 3.4 NON-COMPLIANCE WITH THESE NETWORK OPERATOR RULES

---

Where a **licensed person**, in connection with any **gasfitting work**:

- (a) Fails to comply with these **Rules** in any respect; or
- (b) Otherwise causes any damage or harm, or a significant risk of such damage or harm, to persons or property,

**Jemena** may:

- i. Suspend or disconnect the gas supply to the relevant premises;
- ii. Authorise another **licensed person** to complete any incomplete **gasfitting work** at the relevant premises;
- iii. Complete any incomplete **gasfitting work** itself and recover the reasonable cost of doing so from the **licensed person**;
- iv. Inform Fair Trading NSW for possible action to be taken against the **licensed person**; and/or
- v. **Jemena** reserves the right to withdraw authorisation for **licensed persons** to undertake **gasfitting work** for non-conformance to these **Rules**.

## PART 2: SERVICE PIPING REQUIREMENTS



## TABLE OF CONTENTS

4	NETWORK SERVICE .....	18
4.1	GENERAL .....	18
5	INSTALLATION OR REPAIR WORK CARRIED OUT ON THE CONSUMER SERVICE.....	19
5.1	GENERAL .....	19
5.2	STANDARDS FOR CONSUMER SERVICE PIPE.....	20
5.3	JEMENA NETWORK MAOP.....	20
5.4	MATERIALS.....	20
5.5	REPAIR OF CONSUMER SERVICE .....	22
5.6	SIZING THE CONSUMER SERVICE.....	22
5.7	DUAL OCCUPANCY INSTALLATIONS.....	25
5.8	MAXIMUM ALLOWABLE PRESSURE DROP .....	26
5.9	STANDBY ARRANGEMENTS .....	26
5.10	LEAK TESTING THE CONSUMER SERVICE.....	26
5.11	PIPEWORK AND COMPONENTS NOT SUBJECTED TO THE LEAK TEST .....	27
5.12	PURGING.....	27
5.13	PATH VALVE .....	28
5.14	METER CONTROL VALVES .....	29

## 4 NETWORK SERVICE

### 4.1 GENERAL

**Jemena** will provide a **network service** to a point in the public thoroughfare approximately 225mm outside the **property boundary**. That point will normally be located where the **property boundary** is closest to the **gas main** unless otherwise agreed and approved by **Jemena**. For single residential properties **Jemena** may also install the **consumer service** to the meter location.

A **consumer** is not entitled to more than one **network service** to any one continuous property.

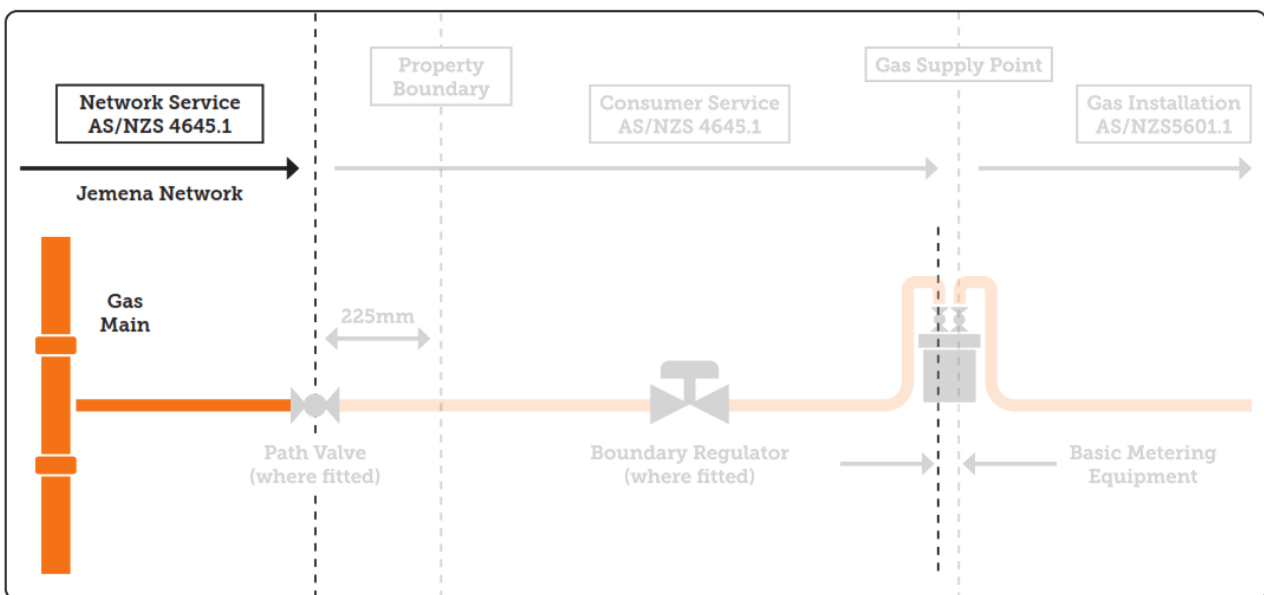

**Figure 2: Network service highlighted**

If a **network service** is needed in a different location to that normally provided and the work is not being performed on behalf of **Jemena**, the **licenced person** must ask **Jemena** for approval for the alternative location. Where it is necessary to re-locate a **network service**, the **licenced person** must ask **Jemena** for a quotation for all charges involved in performing the re-location before starting any **gasfitting work** on the **consumer's** property.

No person is permitted to alter or interfere with a **network service** without specific approval from **Jemena**, except where a hazard may exist. In this instance, temporary repairs may be carried out to reduce the hazard until **Jemena** personnel arrive to make a permanent repair. **Jemena** must be notified immediately by phone on 131 909.

## 5 INSTALLATION OR REPAIR WORK CARRIED OUT ON THE CONSUMER SERVICE

### 5.1 GENERAL

The **consumer service** connects the **network service** to the **gas installation**.

The following conditions must be met:

- (a) The **consumer service** must end so that it can connect with the **network service** approximately 225 mm outside the **property boundary** in the public footpath or thoroughfare;
- (b) If required, the **consumer service** must terminate with a Jemena approved **path valve** (see *Section 5.13 – Path Valve*);
- (c) The **consumer service** must terminate on the meter end with a **meter control valve** (see *Section 5.14 – Meter Control Valves*);
- (d) Where possible the terminal of the **consumer service** should be at right angles to the line of the **gas main**;
- (e) Where possible there should be no poles, pits, manholes or other obstructions between the terminal of the **consumer service** and the **property boundary**; and
- (f) The depth of the **consumer service** at the property boundary must be:
  - a. no less than 600mm from the ground surface for installations in new developments (450mm if in rock);
  - b. no less than 450mm from the ground surface for installations in existing properties (300mm if in rock); and
  - c. at least 50mm clearance between the top of any **path valve** spindle and the finished ground level.

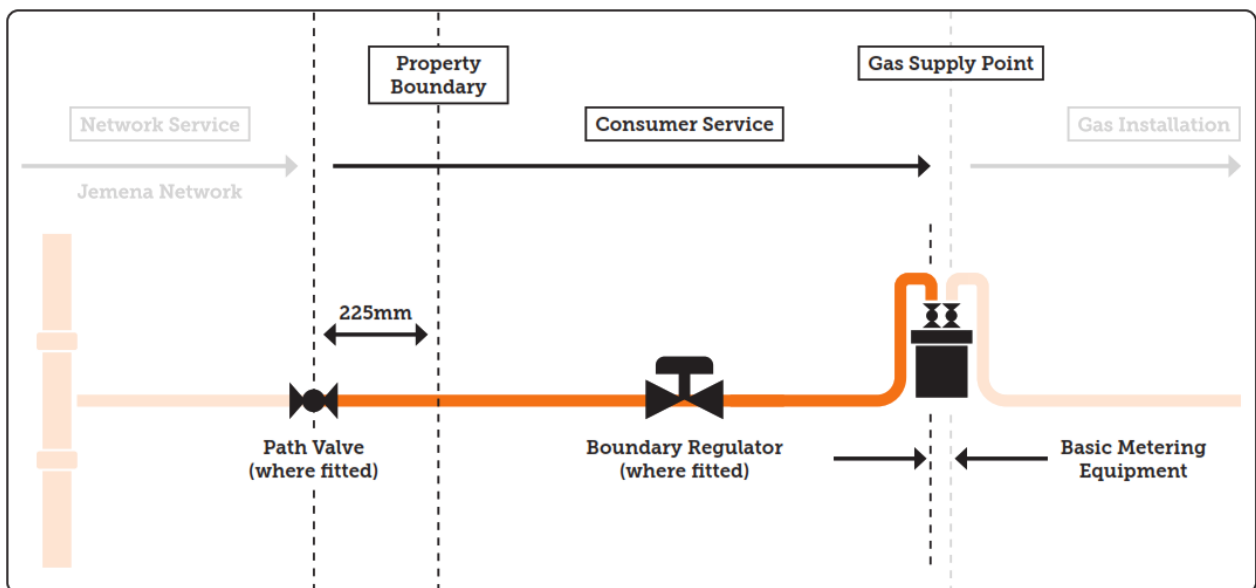

Figure 3: Components of a gas connection

## 5.2 STANDARDS FOR CONSUMER SERVICE PIPE

---

The installation, repair or replacement of a **consumer service** pipe must be performed in accordance with the requirements of AS/NZS 4645 - *Gas distribution networks* (series comprising AS/NZS 4645.1 *Network Management*, AS/NZS 4645.2 *Steel Pipe Systems* and AS/NZS 4645.3 *Plastic Pipe Systems*).

## 5.3 JEMENA NETWORK MAOP

---

**Jemena** operates the gas network at a number of different pressures; below is a list of **MAOPs** in operation:

- (a) 1050kPa (**Gasfitting work** on the 1050kPa network is prohibited)
- (b) 400kPa
- (c) 300kPa
- (d) 210kPa
- (e) 100kPa
- (f) 30kPa
- (g) 7kPa
- (h) 2kPa

Prior to commencing **gasfitting work** the **licenced person** must confirm with Jemena (see *Part 1 Section 1.7 – Contact Details*) the **MAOP** of the network supplying the property.

## 5.4 MATERIALS

---

### 5.4.1 BURIED PIPING

Materials of construction for a buried **consumer service** shall be one of the following:

- (a) Copper or copper alloy (Type A or B) as per AS 1432 - *Copper tubes for plumbing, gasfitting and drainage applications*;
- (b) Stainless steel (Grade 316) as per AS 5200.053 – *Stainless steel pipes and tubes for pressure applications*;
- (c) Polyamide (Class 300) as per AS 2944.1 - *Plastics pipes and fittings for gas reticulation - Polyamide pipes*;
- (d) Polyamide (Class 400) as per AS 2944.1 - *Plastics pipes and fittings for gas reticulation - Polyamide pipes*; or
- (e) Polyethylene (SDR 7.4 & 11) as per AS/NZS 4130 - *Polyethylene (PE) pipes for pressure applications*.

Joining of PE with sizes 20mm, 40mm and 63mm must be done using Electrofusion. Pipe must be prepared using rotary scrapers and pipe and fittings cleaned using alcohol wipes. Alignment clamps must be used during joining.

20mm PE shall be SDR 7.4, all other sizes shall use SDR 11.

#### 5.4.2 ABOVEGROUND PIPING (EXTERNAL)

Any part of a **consumer service** which is exposed to atmosphere and outside the confines of a building, shall be constructed of one of the following:

- (a) Copper or copper alloy (Type A or B) as per AS 1432 - *Copper tubes for plumbing, gasfitting and drainage applications*; or
- (b) Stainless steel (Grade 316) as per AS 5200.053 – *Stainless steel pipes and tubes for pressure applications*.

#### 5.4.3 PIPING IN BUILDINGS (INTERNAL)

Materials of construction for a **consumer service** within a building shall be one of the following:

- (a) Copper or copper alloy (Type A or B) as per AS 1432 - *Copper tubes for plumbing, gasfitting and drainage applications*;
- (b) Stainless steel (Grade 316) as per AS 5200.053 – *Stainless steel pipes and tubes for pressure applications*;
- (c) Composite piping (polyethylene/aluminium/polyethylene or cross-linked polyethylene/aluminium/ cross-linked polyethylene or cross-linked polyethylene/aluminium/polyethylene) as per AS 4176.8 – *Multilayer pipe systems for consumer gas installations with a maximum operating pressure up to and including 5 bar (500kPa)*; or
- (d) Composite piping (cross-linked polyethylene) as per AS/NZS 2492 – *Cross-linked polyethylene (PE-X) pipes for pressure applications*.

##### 5.4.3.1 Additional Requirements for Composite Piping

Where composite piping is used prior to the outlet of **basic metering equipment**, an automatic shutdown shall be installed upstream of the composite piping. The shutdown will be configured with an interlock which causes the gas supply to shut down and lockout if pressure in the **consumer service** is lost.

#### 5.4.4 PROHIBITED MATERIALS

**Jemena** prohibits the use of:

- (a) Anaerobic thread sealants, with the exception of Loctite® 567™;
- (b) PVC piping and fittings;
- (c) Copper/copper alloy flared compression operating above 7kPa; and
- (d) Push connect style fittings (see Figure 4)



**Figure 4: Push connect style fitting**

#### 5.4.5 MATERIAL OPERATING PRESSURE

The maximum operating pressure of a **consumer service** shall be dependent on the material used to construct the **consumer service**, as per Table 1 below:

**Table 1: Maximum operating pressure of various consumer service materials**

Consumer Service Material	Maximum Operating Pressure (kPa)
Copper or copper alloy (Type A or B)	400
Stainless steel (Grade 316)	400
Polyamide (Class 300)	300
Polyamide (Class 400)	400
Polyethylene (SDR 7.4 or 11)	400
Composite Piping (all types)	7

### 5.5 REPAIR OF CONSUMER SERVICE

---

**Jemena** is not responsible or liable for the cost of repair to the **consumer service**. If the repair is carried out by **Jemena** with the approval of the property owner the cost of repair will be passed through to the property owner.

### 5.6 SIZING THE CONSUMER SERVICE

---

A **consumer service** may be sized using the method provided in AS/NZS5601.1 or other recognised method.

For existing premises where additional gas load is required, the existing **consumer service** and **basic metering equipment** should be checked to ensure that adequate capacity is available for the additional load.

The following information will be required for pipe sizing:

- (a) Heating value of the natural gas (if unknown, assume 38 MJ/m<sup>3</sup>);
- (b) Sum of gas consumption from each appliance (MJ/h);
- (c) An allowance, if any, where there is a probability that not all appliances will be used at the same time;
- (d) The **MAOP** available at the start of the **consumer service**. Apply through the gas portal (see *Part 1 Section 1.7 – Contact Details*);
- (e) The allowable pressure drop. Refer to *Section 5.8 – Maximum Allowable Pressure Drop* below; and
- (f) The proposed layout of the **consumer service**, including all pipe lengths and the location of **basic metering equipment**.

## 5.6.1 MULTIPLE RESIDENTIAL DWELLINGS

Where more than one (1) residential dwelling is present at an address (e.g. town houses, high rise etc.), the following diversity factors can be applied to the predicted load (MJ/h) prior to sizing of the consumer service **(For centralised hot water systems include the maximum hot water system load (already) diversified in accordance with AS3500.4 in addition to the below cooktop loads):**

**Table 2: Diversity Factors for Multiple Residential Dwellings**

Number of Dwellings	Diversity Factor Used	Cooktop Load Only MJ/hr	Individual Continuous Flow Hot Water + Cooktop MJ/hr
2	0.730	59	291
3	0.702	85	420
4	0.674	108	537
5	0.650	130	647
6	0.624	150	746
7	0.602	169	839
8	0.590	189	940
9	0.559	202	1002
10	0.540	216	1075
11	0.522	230	1143
12	0.506	243	1209
13	0.482	251	1247
14	0.475	266	1324
15	0.460	276	1374
16	0.447	287	1424
17	0.434	296	1469
18	0.421	304	1509
19	0.409	311	1547
20	0.398	319	1585
21	0.387	326	1618
22	0.377	332	1651
23	0.367	338	1680
24	0.357	343	1706
25	0.348	348	1732
26	0.341	355	1765
27	0.332	359	1784
28	0.326	366	1817
29	0.317	368	1830
30	0.310	372	1851
31	0.303	376	1870
32	0.298	382	1898
33	0.292	386	1918
34	0.286	389	1936
35	0.281	394	1958
36	0.276	398	1978
37	0.272	403	2003
38	0.268	408	2027

39	0.264	412	2049
40	0.260	416	2070
41	0.256	420	2089
42	0.252	424	2107
43	0.248	427	2123
44	0.245	432	2146
45	0.242	436	2168
46	0.239	440	2188
47	0.236	444	2208
48	0.233	448	2226
49	0.231	453	2253
50	0.229	458	2279
51	0.227	464	2304
52	0.225	468	2329
53	0.223	473	2352
54	0.221	478	2375
55	0.219	482	2397
56	0.217	487	2419
57	0.216	493	2451
58	0.214	497	2470
59	0.212	501	2490
60	0.211	507	2520
61	0.209	510	2538
62	0.207	514	2554
63	0.206	520	2583
64	0.205	525	2611
65	0.204	531	2639
66	0.203	536	2667
67	0.203	545	2707
68	0.202	550	2734
69	0.201	555	2760
70	0.200	560	2786
71	0.199	566	2812
72	0.199	574	2852
73	0.198	579	2877
74	0.198	587	2916
75	0.197	591	2941
76	0.197	599	2980
77	0.196	604	3004
78	0.196	612	3043
79	0.196	620	3082
80	0.195	624	3105
<b>80+</b>	<b>0.195</b>	<b>40 MJ/apartment</b>	<b>199 MJ/apartment</b>

**For centralised hot water systems include the maximum hot water system load (already diversified in accordance with AS3500.4 in addition to the above cooktop loads**



## 5.7 DUAL OCCUPANCY INSTALLATIONS

Dual occupancy installations are residential customers that have two dwellings with separate billing on the same block e.g. granny flats. There are two variations: developments constructed at the same time as the main dwelling, and those constructed as an extension.

**Basic metering equipment** for dual occupancy installations shall be fitted in one of two configurations as shown in Figures 5 a) & b) to accommodate these two variations:

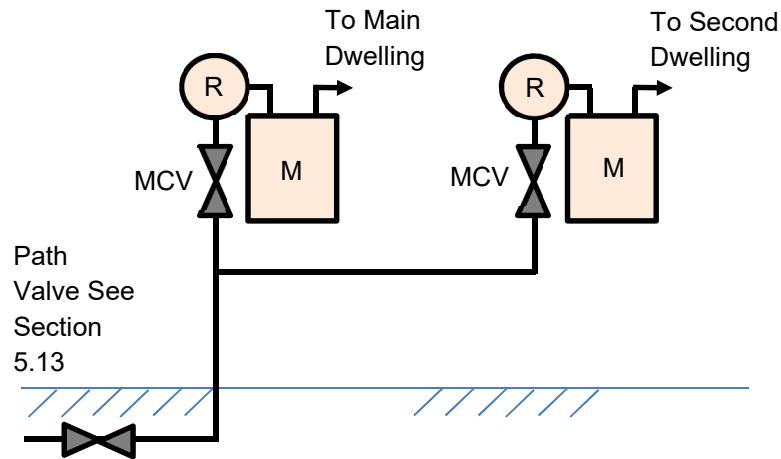

Figure 5 a): New development configuration

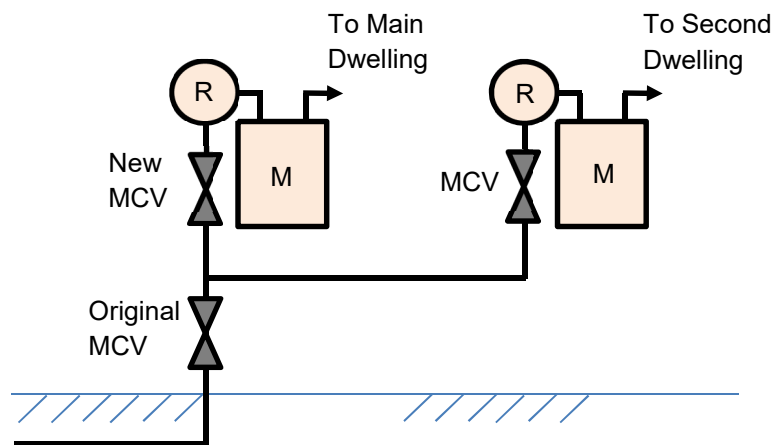

Figure 5 b): Extension configuration

The two billing meters shall be positioned no more than two (2) metres apart, unless otherwise approved by **Jemena**.

Where space restrictions prevent the above configurations, **Jemena** may be contacted to arrange a **standby** (see *Part 1 Section 1.7 – Contact Details*). Charges will apply.

## 5.8 MAXIMUM ALLOWABLE PRESSURE DROP

---

Maximum pressure loss between the **path valve** (225mm outside the **property boundary**) and **basic metering equipment** shall be as per Table 3 below.

**Table 3: Maximum allowable pressure drop for various pressures**

Supply Pressure (kPa)	Maximum Allowable Pressure Drop (kPa)
$0 < \text{MAOP} \leq 7$	0.1
$7 < \text{MAOP} \leq 30$	0.5
$30 < \text{MAOP} \leq 100$	5
$100 < \text{MAOP} \leq 210$	10
$210 < \text{MAOP} \leq 400$	20

## 5.9 STANDBY ARRANGEMENTS

---

Where **gasfitting work** is being performed by the **licenced person**, at least 10 working days' advance notice must be given when requesting **Jemena standby** arrangements for repairs or alterations to a **consumer service**. The applications are received and processed through the gas portal system (see *Part 1 Section 1.7 – Contact Details*). Charges apply for this service.

**Jemena standby** will provide isolation of a **consumer service**, a point of connection for the **consumer service (network service)** and reinstatement of supply once repair/alteration of a **consumer service** is complete. All other **gasfitting work** (including excavation) performed on the **consumer service** shall be by the **licenced person**.

## 5.10 LEAK TESTING THE CONSUMER SERVICE

---

A new, altered or extended **consumer service** must be tested for gas tightness using the methods provided in AS/NZS 5601.1.

The following additional requirements shall be adhered to:

- Leak testing must be against approved testing valves or sealed caps and must not be against process valves that are connected to a **network service** (e.g. live **path valve**) or squeeze off clamps;
- Connect a suitable pressure gauge and pressurise the **consumer service** with air or nitrogen to 1.5 times the **MAOP**, but not less than 35 kPa;
- If a **boundary regulator** is installed, the **consumer service** downstream of the **boundary regulator** shall be subject to a test pressure 1.5 times the set point of the **boundary regulator** pressure relief valve or OPSO, whichever is the greater;
- Isolate the pressure source and allow a suitable period of time for the temperature of the testing medium within the **consumer service** to stabilise. The period for temperature stabilisation will depend on a number of conditions including ambient temperature, test fluid temperature and proposed length of test period;

- (e) For **consumer services** with a volume not exceeding 30L (0.03m<sup>3</sup>), there is to be no loss of pressure during a test period of 15 minutes; and
- (f) Where the pipe volume exceeds 30L, the test period required in (e) is to be extended by 15 minutes for every additional 30L or part thereof.

## 5.11 PIPEWORK AND COMPONENTS NOT SUBJECTED TO THE LEAK TEST

---

Joints that cannot be tested for gas soundness as part of the **consumer service** leak test (e.g. final tie-in), must be tested with leakage detection fluid in the following manner:

- (a) Ensure that the section or joint is pressurised to operating pressure;
- (b) Spray leakage detection fluid over entire joint/s;
- (c) Check for leaks by visually inspecting joints for bubbling or foaming; and
- (d) Repair any joints or replace any defective fittings, components or pipe that indicates a leak, and re-test.

## 5.12 PURGING

---

The **consumer service** must be purged independently of the **basic metering equipment**.

Purging is carried out to avoid the possibility of an explosive air/gas mixture existing within the pipework. Purging is the displacement of:

- (a) Air, or an inert gas, by a fuel gas; or
- (b) A fuel gas by air, or an inert gas.

Nitrogen is the preferred inert gas.

### 5.12.1 PRECAUTIONS BEFORE PURGING COMMENCES

The following precautions / tasks should be undertaken before purging commences:

- (a) Field risk assessment;
- (b) Do not commence any purging operation until a purge area has been defined, made safe and cleared of all **ignition sources**, e.g. naked flames, pilot lights, electrical switchgear, etc.; and
- (c) Do not allow smoking, mobile phones or other **ignition sources** in or near the purge area.

### 5.12.2 PURGING A SMALL VOLUME INSTALLATION WITH GAS TO REMOVE AIR

A small volume installation is one where the total installed pipe volume does not exceed 0.03 m<sup>3</sup> (30L).

#### 5.12.2.1 Recommended Purge Procedure

- (a) Plan a method of purging (see *Section 5.12.2.2- Methods of Purging*) that will ensure no pockets of air will be left within any part of the **consumer service**;
- (b) Ensure that there are no open ends;
- (c) Ensure the area is well ventilated, unconfined and free of possible **ignition sources**, mechanical air inlets or other potential hazards;

- (d) Where adequate ventilation cannot be assured, use flexible piping to direct the purged gas to a suitable open area;
- (e) Any branches off the main run will also require separate individual purging. Ensure such branches are fitted with a plug or cap; and
- (f) Ensuring the minimum velocity of gas flow within pipes is greater than 0.6m/s to minimise mixing of air and gas during purges.

#### 5.12.2.2 Methods of Purging

To ensure a complete purge one of the following methods must be used:

- (a) Purge burner;
- (b) Gas detector; or
- (c) Timed purge.

Purging must be conducted as a single continuous process from start to end.

#### 5.12.3 PURGING A LARGE VOLUME INSTALLATION WITH GAS TO REMOVE AIR

A large volume installation is one with a total installed pipe volume exceeding 0.03m<sup>3</sup> (30L).

Where the volume of the pipe exceeds 0.03m<sup>3</sup> **Jemena** must be contacted for approval of a suitable method.

### 5.13 PATH VALVE

---

A **path valve** must be installed by the **licenced person** when:

- (a) The **consumer service** enters a building;
- (b) The **basic metering equipment** is difficult to reach in an emergency (e.g. where it is located inside a building, or behind a locked gate);
- (c) The pipework connecting the premises to the **network service** crosses private land not included in the title of the property served;
- (d) Two or more **consumer service** risers are extended to different floor levels of a multi-storey building;
- (e) **Consumer service** will supply a new dual occupancy development (see *Section 5.7 – Dual Occupancy Installations*); or
- (f) The **consumer service** is for high rise / medium density / commercial and industrial buildings.

#### 5.13.1 PATH VALVE LOCATION AND DESIGN

A **path valve** must be of the quarter turn type and located below ground in an accessible place in the public thoroughfare 225mm out from the **property boundary**. **Path valves** must be certified with AGA, SAI Global, IAPMO or other accredited body. **Path valves** must be spherical ball design and tested at the maximum test pressure for its location. The valve drive must be a 40mm tall square head socket and meet the standard dimensions of 28.5mm square at the top tapering to 31.75mm at the base.

**Path valves** shall be constructed of bronze or dezincified brass. **Path valves** up to 50mm in size shall be furnished with AS ISO 7.1 BSP female tapered thread connections. Above this size **path valves** shall be furnished with ASME/ANSI B16.5 Class 150 flanges.

### 5.13.2 PATH VALVE TRANSITION PIECE

Where a **path valve** is to be connected to a nylon or polyethylene **consumer service**, a copper transition piece shall be fitted both inlet and outlet of the **path valve**.

### 5.13.3 VALVE BOX AND COVER

The **path valve** must be located in a valve box. The valve box must have a hinged or removable lid, identified by the letter 'G' or 'Gas' on the top. The valve box cover must be flush with the finished ground surface.

## 5.14 METER CONTROL VALVES

---

The **licenced person** must provide a **meter control valve** on the end of the riser when they install the **consumer service**.

**Meter control valves** must be of the quarter turn type. The valve must be certified with AGA, SAI Global, IAPMO or other accredited body. The valve must be spherical ball design and tested at the maximum test pressure for its location. The valve must be lever operated.

The valve shall be constructed of bronze, dezincified brass or stainless steel. **Meter control valves** up to 50mm in size shall be furnished with AS ISO 7.1 BSP female tapered thread connections. Above this size **meter control valves** shall be furnished with ASME/ANSI B16.5 Class 150 flanges.

**Meter control valves** located inside buildings that are not fitted with **master isolation valves** (see *Section 5.14.1 – Master Isolation Valves*) shall be labelled with signage nearby indicating the following:

To isolate gas supply in case of emergencies, close <b>VALVE</b> For Gas Emergency, call 131 909
---

The signage shall be provided by the building owner or their authorised representative. The signage design (font style, size and spacing, colour etc) must comply with *AS/NZS 1319 – Safety signs for the occupational environment*.

### 5.14.1 MASTER ISOLATION VALVES

Wherever a **consumer service** enters a building and the **basic metering equipment** does not comply with *Part 3 Section 6.4.4.1 (d) & (e)* or *Part 3 Section 6.4.4.2 (b) & (c)*, a **master isolation valve** shall be installed on the **consumer service**. This is in addition to the **meter control valve** and **path valve**. The **master isolation valve** shall be installed in a cabinet or cavity on the outside of the building as close as possible to the building entry point in an easily accessible location and shall be fitted with signage containing the following notes:

To isolate gas supply in case of emergencies, close <b>VALVE</b> For Gas Emergency, call 131 909
---

The signage shall be provided by the building owner or their authorised representative. The signage design (font style, size and spacing, colour etc) must comply with *AS/NZS 1319 – Safety signs for the occupational environment*.

## PART 3: BASIC METERING EQUIPMENT

## TABLE OF CONTENTS

6	BASIC METERING EQUIPMENT .....	32
6.1	GENERAL .....	32
6.2	BASIC METERING EQUIPMENT LOCATION REQUIREMENTS .....	32
6.3	BOUNDARY REGULATORS .....	34
6.4	INSTALLATION .....	34
6.5	HAZARDOUS AREA CLASSIFICATION .....	39
6.6	BASIC METERING EQUIPMENT IN HIGH RISE BUILDINGS .....	40
6.7	VENTILATION OF AN ENCLOSURE .....	41
6.8	EXCLUSION ZONES FOR BASIC METERING EQUIPMENT .....	43
6.9	RELIEF VENT .....	44
6.10	OUTLET METER PRESSURE FOR SIZING CONSUMER PIPING SYSTEM .....	46
6.11	METER IDENTIFICATION .....	46
6.12	METER BY-PASS .....	46
6.13	METER OPERATING PRESSURE .....	46
6.14	METER HANDLING .....	47
6.15	METER CHANGE / METER UPGRADE .....	47
6.16	RETURNING A GAS METER .....	47
6.17	PERMANENT DISCONNECTIONS .....	48
6.18	SAFETY SHUT OFF SYSTEMS .....	48
7	APPENDICES .....	49
7.1	TRAFFIC PROTECTION BARRIERS .....	49
7.2	CLEARANCE FROM OTHER UTILITIES .....	50
7.3	TYPE 1 ENCLOSURE REQUIREMENTS .....	51
7.4	TYPE 2 ENCLOSURE REQUIREMENTS .....	53

## 6 BASIC METERING EQUIPMENT

### 6.1 GENERAL

---

All work carried out to install or replace all, or any part of, **basic metering equipment** must be in accordance with *AS/NZS 4645.1 – Gas Distribution Networks (Network Management)*, any other applicable Australian Standard, the **Gas Supply Regulation** and these **Rules**.

Any person installing or replacing all, or any part of, **basic metering equipment** owned or managed by **Jemena**, must meet the relevant criteria before undertaking the work as prescribed in *Part 1 Section 2 – Performing Gasfitting Work* of these **Rules**.

**Basic metering equipment** is issued by Jemena in the form of:

- (a) **Boundary regulators**;
- (b) **Meter kits**; and
- (c) **Meter sets**.

**Boundary regulators**, **meter kits** and **meter sets** are issued to the installer by **Jemena** as pre-designed, prefabricated assemblies equipped with all necessary fittings and components to be able to supply gas in accordance with specifications and procedures.

**Boundary regulators**, **meter kits** and **meter sets** have their outlet pressure adjustments sealed to prevent unauthorised adjustment. The regulator setting must not be altered without prior approval from **Jemena**. Depending upon the connected gas load (appliances) and available supply pressure, the standard regulator settings are 1.38kPa, 2.75kPa, 5kPa, 35kPa or 100kPa.

#### 6.1.1 OPERATING PRESSURE IN BUILDINGS

The **consumer service** entering an **enclosure** may operate at the pressure levels listed in *Part 2 Section 5.3 – Jemena Network MAOP*. If the **consumer service** exiting the enclosure supplies **Jemena basic metering equipment**, the gas pressure exiting the **enclosure** must be equal or less than 7kPa, unless explicitly approved otherwise by **Jemena** prior to final design.

If the piping exiting the enclosure is part of the **consumer piping**, the pressure should conform to AS/NZS5601.1.

For acceptable positioning of **enclosures** in a building, refer to *Section 6.4.4.1 – Meter Kit Internal Installation* and *Section 6.4.4.2 – Meter Set Internal Installation*.

### 6.2 BASIC METERING EQUIPMENT LOCATION REQUIREMENTS

---

**Basic metering equipment** shall be located as follows:

- (a) In the open, located externally from a building;
- (b) In a ventilated **enclosure**, positioned with access door(s) on the external wall of the building, with the **enclosure** sealed from the remainder of the building;
- (c) In a ventilated **enclosure**, sealed from the remainder of the building and ventilated to the outside, with sealed access door(s) into the inside of the building;

The requirements of (b) and (c) above may be modified if inlet pressure to **basic metering equipment** is equal or less than 7kPa.



Where the above cannot be achieved, **Jemena** shall be consulted (see *Part 1 Section 1.7 – Contact Details*).

Basic metering equipment locations shall comply with *Section 6.2.2– Prohibited Basic Metering Equipment Locations*.

#### 6.2.1 BASIC METERING EQUIPMENT LOCATIONS FOR RESIDENTIAL PROPERTIES LOCATED WITHIN A NEW ESTATE

For new estates reticulated with underground electricity, the **basic metering equipment** shall be located on the same side of the property as the electrical pillar box.

#### 6.2.2 PROHIBITED BASIC METERING EQUIPMENT LOCATIONS

In accordance to these **Rules** and subject to the additional requirements of *AS/NZS 4645.1 - Gas Distribution Network (Network Management)*, **basic metering equipment** must not be installed in the following locations:

- (a) In a location where commercial, household items, including combustible or discarded materials are stored around or in-front of the **basic metering equipment** restricting access of **Jemena's** meter readers and maintenance crews;
- (b) Shall not be used as storage racks. No items (e.g., mop, broomstick, ladder, garbage bin) shall be rested on or stored in close proximity;
- (c) Near a location where chemicals or corrosive agents such as chlorine or cleaning agents are stored or frequently used;
- (d) In a room in which an unsealed grease trap is located;
- (e) Near a **source of ignition**, refer *Section 6.8 – Exclusion Zones for Basic Metering Equipment*;;
- (f) Near LPG bottles;
- (g) A lift shaft or lift motor room;
- (h) A room specifically intended for electrical switchgear;
- (i) A fire-isolated stairway or passage;
- (j) A fire hydrant duct or hose reel cabinet;
- (k) A sprinkler or hydrant pump room;
- (l) In a position that would obstruct egress from a building;
- (m) In a position where the **basic metering equipment** would be subject to physical damage unless adequately protected;
- (n) In an area where excessive temperatures or sudden excessive changes in temperature may occur;
- (o) In an area of excessive vibration;
- (p) In the foundation area under a building;
- (q) In a cavity wall, unless installed in a ventilated **enclosure** with external access and the cavity is sealed;
- (r) In an unventilated position;
- (s) On the ground, or on a floor which is frequently wetted or on a floor which contains material which may corrode the **basic metering equipment**;

- (t) Where a service riser is not separated from an earth electrode by 500mm; and
- (u) A ceiling space

For additional requirements on the prohibited locations of the **basic metering equipment**, refer to *AS/NZS 4645.1 - Gas Distribution Network (Network Management)*.

### 6.2.3 ACCESS TO BASIC METERING EQUIPMENT

**Jemena** requires unimpeded 24hr access to its **basic metering equipment** in the event of an emergency. All **basic metering equipment** must be installed in easily accessible locations. Where **basic metering equipment** is installed behind common property locked doors or security controlled elevators, a suitable access solution must be implemented. Unless otherwise approved by **Jemena**, the following access solutions shall be implemented.

- (a) All common property doors shall have either a static dual lock with an **ABLOY PROTEC** locking system installed or an **ABLOY PROTEC** override switch fitted to the fire indicator panel (FIP).
- (b) All common property elevators shall have an **ABLOY PROTEC** control switch installed to enable operation of elevator to all levels that have **basic metering equipment**.

## 6.3 BOUNDARY REGULATORS

---

**Boundary regulators** are installed on **consumer services** to reduce the supply pressure entering a building. They are typically used where internal reticulation of the building is required to supply multiple **consumers** e.g. high rise, shopping centres. **Boundary regulators** reduce the potential for (and limit the consequence of) gas escapes within a building.

The rules for prohibited locations applying to **basic metering equipment** also apply to **boundary regulators**. Refer to *Section 6.2.2 – Prohibited Basic Metering Equipment Locations*.

The rules for **meter kit** and **meter set** installations also apply to **boundary regulators**.

**Boundary regulators** are available as kits and sets.

## 6.4 INSTALLATION

---

### 6.4.1 GENERAL

**Meter kits** must be installed in accordance with the installation instructions provided in the **meter kit** packaging.

**Meter sets** are supplied by **Jemena** and must be installed in accordance with these **Rules** and the applicable **Jemena** drawing(s) and instructions.

Where a **meter kit** is not installed by an authorised **Jemena** representative, a **licenced person** may commission a **meter kit** once **Jemena** has issued a meter for the installation. **Meter sets** are delivered to **consumer** premises by **Jemena's** authorised contractors and, once installed, commissioned by authorised **Jemena** personnel. **Meter sets** may be commissioned by a **licenced person** under the supervision of authorised **Jemena** personnel.

The **licenced person** needs to provide **Jemena** with a leak test certificate and certificate of compliance in accordance with *Part 1 Section 3 – Completion of Gasfitting Work* after installation of **basic metering equipment** for **Jemena** to issue a meter. No meter will be issued unless the **licenced person** has met all **Jemena's** installation requirements and certificates provided.

The **basic metering equipment** shall be:

- (a) located to ensure noise is controlled to comply with requirements of any relevant authority;
- (b) located in a position where it is not at risk of physical damage from nearby vehicular traffic, etc., unless it is adequately protected. Specifically, mechanical protection must be installed where the **basic metering equipment** location is within one (1) metre of roads, driveways, car parking areas, garages, loading docks etc., or other areas where there is mobile plant, equipment or vehicles moving within one (1) metre of the **basic metering equipment** location. Mechanical protection shall be designed to the requirements of *AS/NZS 1170.1 – Structural design actions (permanent, imposed and other actions)*. See *Section 7.1 – Example of Appropriate Safety Barrier*;
- (c) installed so that the base of the meter is above finished ground level;
- (d) any damaged floor and/or wall which supports or provides passage to gas pipework shall be repaired;
- (e) ensure all gas pipework is clearly labelled or identified by signage;
- (f) installed clear from other utility assets. See *Section 7.2 – Clearance from Other Utilities*.

## 6.4.2 METER KITS

### 6.4.2.1 Meter Kit Supports

**Meter kits** shall be supported on the approved meter bar provided in the kit. The weight of the meter must not put any strain on the connecting piping.

### 6.4.2.2 Minimum Height and Spacing Requirement

**Meter kits** must be installed with the minimum height and spacing requirements as stated in the installation instruction provided in the kit box.

Meters must not be installed higher than 1700mm from ground level to the top of the meter bar, unless specifically approved by **Jemena**.

## 6.4.3 EXTERNAL INSTALLATION REQUIREMENTS

### 6.4.3.1 Meter Kit External Installation

In addition to the installation requirements specified in *Section 6.4.1 – General*, the following minimum clearances shall be maintained for **meter kits** in an external location:

- (a) The clearance to **source of ignition** (including electrical meter boxes) and building openings shall be in accordance with *Section 6.8 – Exclusion Zones for Basic Metering Equipment*;
- (b) 150mm away from any underground electrical supply cable that is indicated along its length with orange marking tape and is provided with mechanical protection in line within *AS/NZS 3000 - Electrical installations*, or 300mm away from any underground electrical supply cable neither indicated nor mechanically protected;
- (c) 500mm away from any underground electrical earthing electrode for an electrical supply not exceeding 1000 volts. For an electrical supply exceeding 1000 volts, Fair Trading NSW shall be contacted for the clearance requirements;
- (d) 150mm away from any underground communication cable;
- (e) 150mm away from any cable or service other than above; and

- (f) Piping not to be exposed to liquid discharge (e.g. from a water heater relief valve or appliance condensate drain).

Refer to Figure 6 below for illustration of the external installation clearance requirements to underground cables and earthing electrode.

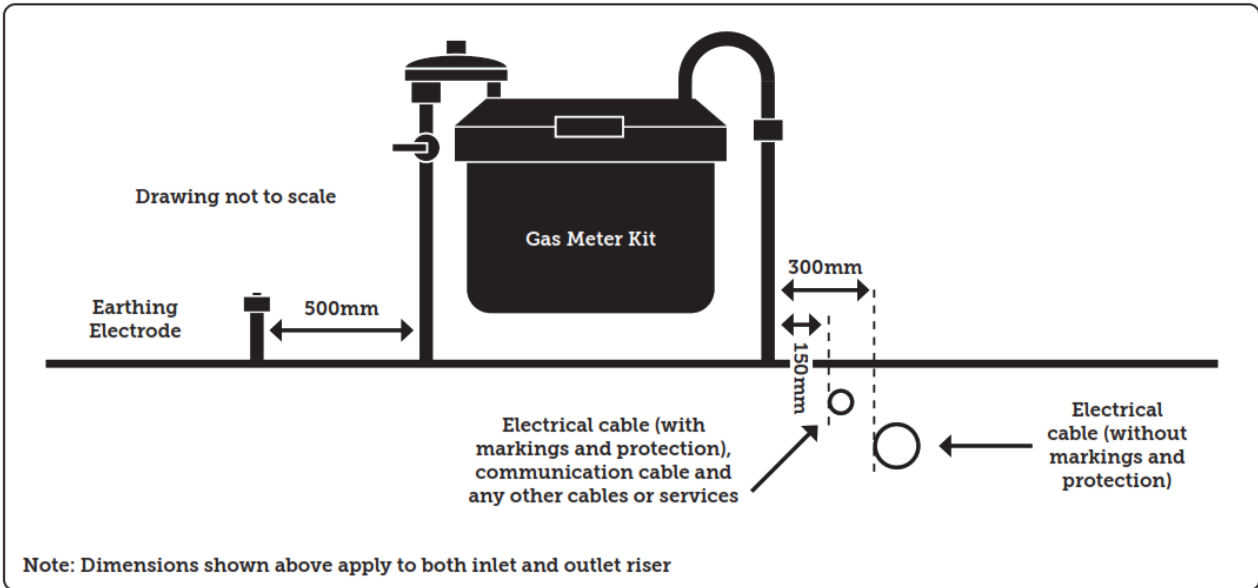

**Figure 6: Kit external installation clearance requirements to underground cables and earthing electrode**

#### 6.4.3.2 Meter Set External Installation

Unless otherwise authorised by **Jemena**, a **meter set** that is installed externally shall be located in a **Type 1 enclosure** complying with the following requirements:

- (a) The location of the **Type 1 enclosure** must be approved by **Jemena** at the site design stage;
- (b) The dimensions and clearances for a **Type 1 enclosure** must be consistent with the drawings in *Section 7.3 – Type 1 Enclosure Requirements* to provide adequate clearance for maintenance work to be performed. This requirement may be varied subject to specific approval from **Jemena**;
- (c) The clearance of the **meter sets** to **source of ignition** (including electrical meter boxes) and building openings shall be in accordance with *Section 6.8 – Exclusion Zones for Basic Metering Equipment*;
- (d) The **Type 1 enclosure** may be fitted with a single egress point where maintenance activities can be undertaken on **basic metering equipment** without the **basic metering equipment** impeding access to the egress point. Refer to *Section 7.3 – Type 1 Enclosure Requirements* for more details;
- (e) The **Type 1 enclosure** must be fitted with signage. The signage shall be provided by the party responsible for erecting the **Type 1 enclosure**. The signage design (font style, size and spacing, colour etc) must comply with *AS/NZS 1319 – Safety signs for the occupational environment*. The signage shall display the following:

NO SMOKING  
 NO ENTRY AUTHORISED PERSONS ONLY  
 DANGER FLAMMABLE GAS  
 IN CASE OF EMERGENCY CALL 131 909

- (f) The design and construction of the **Type 1 enclosure** must not restrict natural ventilation to ensure gas can freely escape;
- (g) The **Type 1 enclosure** must be fitted with a **Jemena ABLOY PROTEC** padlock;
- (h) If **Type 1 enclosure** is constructed of fencing, the fencing shall be designed and installed in accordance to *AS 1725.1- Chain link fabric fencing (Security fences and gates – General requirements)*. For technical requirements of the fencing installation, refer to *Section 7.3 – Type 1 Enclosure Requirements* for more details;
- (i) **Meter set** shall be installed on concrete footings to provide safe working surfaces for maintenance activities, prevent growth of vegetation, i.e., fire hazards, and provide support for fencing (if installed). For technical requirements of the footing installation, refer to *Section 7.3 – Type 1 Enclosure Requirements* for more details;
- (j) **Meter set** may be installed on existing footings, so long as inlet/outlet piping does not impede access to the equipment or pose a trip hazard.

#### 6.4.4 INTERNAL INSTALLATION REQUIREMENTS

##### 6.4.4.1 Meter Kit Internal Installation

Single dwelling (residential) installations with supply pressure >7kPa must not be installed internally.

In addition to the installation requirements specified in *Section 6.4.1 - General*, **meter kits** in an internal location shall be installed within a building/**enclosure** that complies with:

Where gas supply to the **meter kit** is  $\leq 7$ kPa:

- (a) The ventilation requirements shall comply with *AS/NZS 4645.1 - Gas Distribution Networks (Network Management)*, and
  - i. Apply clearances to sources of ignition in accordance with *Section 6.8 – Exclusion Zones for Basic Metering Equipment*; and
  - ii. Ensure the design and location of ventilation openings for the **enclosure** are such that adequate ventilation is achieved in all parts of the enclosed area. Refer to *Section 6.7 – Ventilation of an Enclosure* for the requirements.
- (b) If the ventilation requirements in *AS/NZS 4645.1 - Gas Distribution Networks (Network Management)* cannot be achieved, refer to **Jemena** (see *Part 1 Section 1.7 – Contact Details*) for assessment; and/or
- (c) **Meter kits** installed within high rise buildings shall comply with *Section 6.6 - Basic Metering Equipment in High Rise Buildings*.

Where gas supply to the **meter kit** is >7kPa:

- (d) The **meter kit** shall be installed in an **enclosure** which is sealed from the remainder of the building. The **enclosure** must be within 1 metre of the external wall of a building at the point where the **consumer service** enters the building (point of entry). The **enclosure** shall be ventilated to outside the building;
- (e) The **enclosure** may be located at ground level or one level below ground. However, it must still be positioned adjacent to the external wall of the building as per (d) above;
- (f) The **enclosure** shall be designed to house the **meter kit** only and allow access for **Jemena** personnel to perform maintenance on the **meter kit**.; and
- (g) **Meter kit** relief valve shall be fitted with a vent line which meets the requirements of *Section 6.9 – Relief Vent*.

#### 6.4.4.2 Meter Set Internal Installation

Single dwelling (residential) installations with supply pressure >7kPa must not be installed internally.

Unless otherwise authorised by **Jemena**, a **meter set** that is installed internally shall be located in a **Type 2 enclosure** complying with the following requirements. For **meter sets** in high rise buildings or plant rooms, refer to *Section 6.6 - Basic Metering Equipment in High Rise Buildings*.

- (a) The location of the **Type 2 enclosure** must be approved by **Jemena** at the building/site design stage;
- (b) The **Type 2 enclosure** shall be positioned on the external wall of a building at the point where the **consumer service** enters the building (point of entry) i.e. one (1) wall of the **enclosure** shall be formed by the external wall of the building;
- (c) The **Type 2 enclosure** may be located at ground level or one level below ground. However, it must still be positioned on the external wall of the building as per (b) above;
- (d) The **Type 2 enclosure** must have adequate clearance for maintenance work to be performed. Clearance dimensions shall be as indicated in *Section 7.4 – Type 2 Enclosure Requirements*. This requirement may be varied subject to specific approval from **Jemena**;
- (e) The **Type 2 enclosure** may be fitted with a single egress point where maintenance activities can be undertaken on **basic metering equipment** without the **basic metering equipment** impeding access to the egress point. Refer to *Section 7.4 – Type 2 Enclosure Requirements* for more details;
- (f) The door of the **Type 2 enclosure** shall not impede access into the room; allowing maintenance activities to be undertaken on the **meter set**;
- (g) The building owner or the owner's authorised representative shall be responsible for ensuring no obstructions are placed on either side of the door(s) of the **Type 2 enclosure**;
- (h) Floor of the **Type 2 enclosure** must be constructed of concrete and be level;
- (i) **Meter set** may be installed on existing footings;
- (j) The **Type 2 enclosure** door must be fitted with signage. The signage shall be provided by the **enclosure** owner or their authorised representative. The signage design (font style, size and spacing, colour etc) must comply with *AS/NZS 1319 – Safety signs for the occupational environment*. The signage shall display the following:

NO SMOKING NOT TO BE USED FOR STORAGE NO ENTRY AUTHORISED PERSONS ONLY DANGER FLAMMABLE GAS IN CASE OF EMERGENCY CALL 131909
--

- (k) The **Type 2 enclosure** walls and door(s) must have a fire resistance rating of two (2) hours;
- (l) Where required by the National Construction Code (NCC), the **Type 2 enclosure** will be fitted with a fire sprinkler;
- (m) The **Type 2 enclosure** door(s) must be fitted with an **ABLOY PROTEC** locking system. All doors that provide access to the **enclosure** must be fitted with an **ABLOY PROTEC** locking system (see *Section 6.2.3 – Access to Basic Metering Equipment*);
- (n) The inlet and outlet piping of the **meter set** may run across the floor or onto walls. Any piping on the floor must be physically protected. Physical protection must be ramped to prevent trip hazards;

- (o) Any damaged floor and/or wall which supports or provides passage to gas piping shall be repaired;
- (p) Ensure all gas piping is clearly labelled or identified by signage;
- (q) **Meter set** relief valve shall be fitted with a vent line which meets the requirements of *Section 6.9 – Relief Vent*;
- (r) Ventilation openings which are not directly to the outside i.e. pass through ducts in the building, must be fitted with fire dampers. Fire dampers shall have fusible links. Fire dampers shall be on the **enclosure** side of the duct;
- (s) Where gas supply to the meter set is  $\leq 7\text{kPa}$ :
  - i. The **Type 2 enclosure** shall be ventilated (naturally or mechanically) in accordance with *AS/NZS 4645.1 - Gas Distribution Networks (Network Management)*. Refer to *Section 6.7– Ventilation of an Enclosure* for more details;
  - ii. The clearance of the **meter sets to source of ignition** (including electrical meter boxes) and building openings shall be in accordance with *Section 6.8 – Exclusion Zones for Basic Metering Equipment*;
  - iii. If the ventilation requirements in *AS/NZS 4645.1 - Gas Distribution Networks (Network Management)* cannot be achieved, refer to **Jemena** for assessment (see *Part 1 Section 1.7 – Contact Details*).
- (t) Where gas supply to the meter set is  $> 7\text{kPa}$ :
  - i. The **Type 2 enclosure** shall be ventilated (naturally or mechanically) in accordance with *AS/NZS 4645.1 - Gas Distribution Networks (Network Management)*. Refer to *Section 6.7 – Ventilation of an Enclosure* for more details;
  - ii. The **Type 2 enclosure** shall be classified as a Zone 2 Hazardous Area. Refer to *Section 6.5 – Hazardous Area Classification*;
  - iii. Signage must be placed on the **enclosure** entry door(s) identifying the **enclosure** as a hazardous area. The signage shall be provided by the **enclosure** owner or their authorised representative. The signage design (font style, size and spacing, colour etc) must comply with *AS/NZS 1319 – Safety signs for the occupational environment*. The signage shall display the following:
 

DANGER  
ZONE 2  
HAZARDOUS AREA
  - iv. The building owner or its authorised representative shall be responsible for the maintenance and upkeep of fire protection systems, ventilation equipment and integrity of any vent lines. The maintenance record shall be kept for review by **Jemena** at any time.

## 6.5 HAZARDOUS AREA CLASSIFICATION

---

In accordance with *AS/NZS 60079.10.1 – Explosive Atmospheres (Classification of Areas – Explosive Gas Atmospheres)* **Jemena** will classify some **enclosures** as Hazardous Areas.

An **enclosure** classified as a Hazardous Area shall not contain any **ignition source** of any kind and all electrical equipment installed in the **enclosure** must be certified to operate within a Hazardous Area.



Only **Jemena** specified electrical equipment shall be installed in a classified **enclosure**; this includes light fittings, switches and other associated equipment.

Electrical equipment issued by **Jemena** shall be installed by a qualified EEHA electrician working on behalf of the building owner or its authorised representative.

#### 6.5.1 HAZARDOUS AREA DOSSIER

**Jemena** shall issue a hazardous area dossier for each classified **enclosure**. The dossier contains all documents associated with installing and managing a hazardous area, including the facility to record maintenance of certified electrical equipment.

The building owner or its authorised representative shall be responsible for ensuring the dossier is stored on-site, in a receptacle, and be readily available for **Jemena** personnel to inspect. Failure to comply will result in a non-conformance notice.

## 6.6 BASIC METERING EQUIPMENT IN HIGH RISE BUILDINGS

---

### 6.6.1 GENERAL

Where **basic metering equipment** is located in an **enclosure** in a high rise building, the door of the **enclosure** must not open directly onto a fire stair or fire corridor.

**Jemena** will release gas meters to a site only once mains electrical power has been activated and the Fire Indicator Panel (FIP) energised.

### 6.6.2 RESIDENTIAL METER KITS FOR HIGH RISE BUILDINGS

Residential **meter kits** for high rise buildings shall comply with the following requirements:

- (a) **Meter kits** to be accessible and allow unimpeded access for maintenance and meter reading;
- (b) **Meter kits** for individual apartments may be grouped in a central location. However, they are not permitted to be located within individual apartments;
- (c) **Meter kits** when grouped may be installed in a column configuration to a maximum height of 2200mm from floor to top of **meter kit**;
- (d) **Meter kits** grouped internally in a meter room must comply with *AS/NZS 4645.1 - Gas Distribution Networks (Network Management)* ventilation requirements. Refer to *Section 6.7– Ventilation of an Enclosure* for more details; and
- (e) Must comply with *Section 6.2.2 – Prohibited Basic Metering Equipment Locations*.

### 6.6.3 METERS (RETAIL / COMMERCIAL) IN HIGH RISE BUILDINGS

**Basic metering equipment** for tenancies can be located within common areas or an agreed area within the development. Tenancy meters may be located in groups at a central location or may be in individual locations attached to a ring main. **Basic metering equipment** shall comply with the following requirements:

- (a) Accessible and allow unimpeded access for maintenance and meter reading;
- (b) Must comply with *Section 6.4.4 – Internal Installation Requirements*;
- (c) Located at a height as per the installation instruction of the **basic metering equipment**;
- (d) In a location that is ventilated in accordance to *AS/NZS 4645.1 - Gas Distribution Networks (Network Management)*. Refer to *Section 6.7– Ventilation of an Enclosure* for more details; and



- (e) Must comply with *Section 6.2.2 – Prohibited Basic Metering Equipment Locations*.

#### 6.6.4 METERS LOCATED ON ROOF TOPS

Where **basic metering equipment** is located on a roof top, the building design must consider safe access for service personnel, that complies with the following conditions:

- (a) Access to the roof must be through a standard doorway;
- (b) Not to be installed near an unprotected ledge as per SafeWork NSW guidelines; and
- (c) Consideration is given to lighting, pathway markers, safety barriers, etc.

#### 6.6.5 METERS IN PLANT ROOMS

**Basic metering equipment** with gas supply pressure equal or less than 7kPa may be located in plant rooms in which gas fired equipment is located. The following requirements must be complied with:

- (a) The enclosing walls and door(s) must have a fire resistance rating of two (2) hours;
- (b) The plant room shall be ventilated (naturally or mechanically) in accordance with *AS/NZS 4645.1 - Gas Distribution Networks (Network Management)*. Refer to *Section 6.7– Ventilation of an Enclosure* for more details;
- (c) The plant room may be fitted with a single egress point where maintenance activities can be undertaken on **basic metering equipment** without the **basic metering equipment** or any other equipment in the plant room impeding access to the egress point;
- (d) The clearance of the **basic metering equipment** to gas fired equipment and other **ignition sources** shall be in accordance with *Section 6.8.1 – Exclusion Zones for Low Pressure Basic Metering Equipment*;
- (e) The door of the plant room shall not impede access into the room; allowing maintenance activities to be undertaken on **basic metering equipment**;
- (f) The building owner or the owner’s authorised representative shall be responsible for ensuring no obstructions are placed on either side of the door(s) of the plant room; and
- (g) Refer also to requirements of *Section 6.2.2 – Prohibited Basic Metering Equipment Locations*.

### 6.7 VENTILATION OF AN ENCLOSURE

---

Where an **enclosure** containing **basic metering equipment** is to be ventilated in accordance with *AS/NZS 4645.1 - Gas Distribution Networks (Network Management)*, exhaust air from the enclosure shall be in such a way that it does not create a hazard to the public or to building personnel.

The **enclosure** shall be ventilated by one of the methods below:

- a) For natural ventilation to outside, the following applies:
  - i. Two permanent openings shall be provided directly to outside, each with a minimum free ventilation area provided as calculated;

$$A = R \times F$$

A = the minimum free ventilation area (mm<sup>2</sup>)

R = equipment rated capacity (m<sup>3</sup>/h (gas)) of the **basic metering equipment**

F = 1000 for pressures not exceeding 7 kPa; or

= 2000 for pressures exceeding 7 kPa but not exceeding 200 kPa; or

= 3000 for pressures exceeding 200 kPa but not exceeding 400 kPa

- ii. All or part of the required ventilation may be supplied by air 'leaked' into an **enclosure** through gaps in the structure;
  - iii. Natural ventilation construction must not be of a type that restricts the flow of natural gas to the outside of the **enclosure**. The design must take into account that natural gas is lighter than air to avoid gas entrapment within the **enclosure**;
  - iv. The openings shall be located to ensure the distance between the top of the upper opening and the ceiling of the **enclosure**, and the distance between the bottom opening and the floor of the **enclosure** does not exceed 5% of the height of the **enclosure**;
  - v. The openings shall be located such that the distance between those ventilation openings and any mechanical ventilation air intake to the building is at least three (3) metres;
  - vi. The distance of any ventilation openings shall be at least one (1) metre horizontally and three (3) metres vertically from any opening to the building; and
  - vii. The distance of any **enclosure** ventilation opening and an electrical substation shall be at least three (3) metres in any direction.
- b) For mechanical ventilation, the following applies:
- i. Where the ventilation for the **enclosure** is to be provided by mechanical means, this shall be directly to outside and conform with the minimum airflow to outside calculation as follows:  
$$\text{Minimum airflow to outside in L/min (requires adequate airflow into the enclosure) = equipment rated capacity (m}^3\text{/h (gas))} \times 6$$
  - ii. Fan motors shall be remote from the exhaust duct or be rated to operate in a Zone 1 hazardous area (refer to *AS/NZS 60079.10.1*);
  - iii. The exhaust discharge shall be located such that the distance between the exhaust and any mechanical ventilation air intake to the building is at least three (3) metres;
  - iv. The air intake to the **enclosure** should be located at least three (3) metres from the exhaust discharge of the **enclosure**;
  - v. Ventilation by mechanical means must service the **enclosure** containing the **basic metering equipment** only and not ventilate any other area of the building;
  - vi. The distance of the exhaust discharge shall be at least one (1) metre horizontally and three (3) metres vertically from any opening to the building; and
  - vii. The distance of the exhaust discharge from an electrical substation shall be at least three (3) metres in any direction.
- c) Where a combination of natural and mechanical ventilation is to be used to ventilate an **enclosure**, the following applies:
- i. Exhaust air shall be driven by mechanical means;
  - ii. Minimum airflow shall match the requirements of *Section 5.7 b) i.* above;
  - iii. Fan motors shall be remote from the exhaust duct or be rated to operate in a Zone 1 hazardous area (refer to *AS/NZS 60079.10.1*);
  - iv. No open flued gas appliance shall be installed in the **enclosure**;
  - v. The exhaust discharge shall be located such that the distance between the exhaust and any mechanical ventilation air intake to the building is at least three (3) metres ;

- vi. The distance of the exhaust discharge shall be at least one (1) m horizontally and three (3) m vertically from any opening to the building;
- vii. The natural ventilation openings of the **enclosure** and the mechanical exhaust discharge shall be at least three (3) metres apart; and
- viii. The distance of the exhaust discharge from an electrical substation shall be at least three (3) metres.

## 6.8 EXCLUSION ZONES FOR BASIC METERING EQUIPMENT

### 6.8.1 EXCLUSION ZONES FOR LOW PRESSURE BASIC METERING EQUIPMENT

For low pressure **basic metering equipment** mounted on a wall, the following exclusion zones and clearances apply.

- a) Half cylinder with distances of  $x$  and  $y$  shown in Figure 7 from any openings, e.g., door, window, mechanical air inlets or any other opening into a building where gas can accumulate, measured from the point of gas discharge (e.g. regulator vent or openings from a meter box) of the **basic metering equipment**; and
- b) Half cylinder of dimensions  $x$  and  $y$  shown in Figure 7 from **source of ignition** (including electricity meter box), measured from the point of gas discharge (e.g., regulator vent or openings from a meter box) of the **basic metering equipment**.

The flat side of the half cylinder represents the wall the **basic metering equipment** is mounted on.

For **basic metering equipment** which is not wall mounted, the exclusion zone shall be extended to a full cylinder of radius  $x$  centred on the point of discharge, with the same clearance requirements of *Section 6.8.1 a) & b)* above.

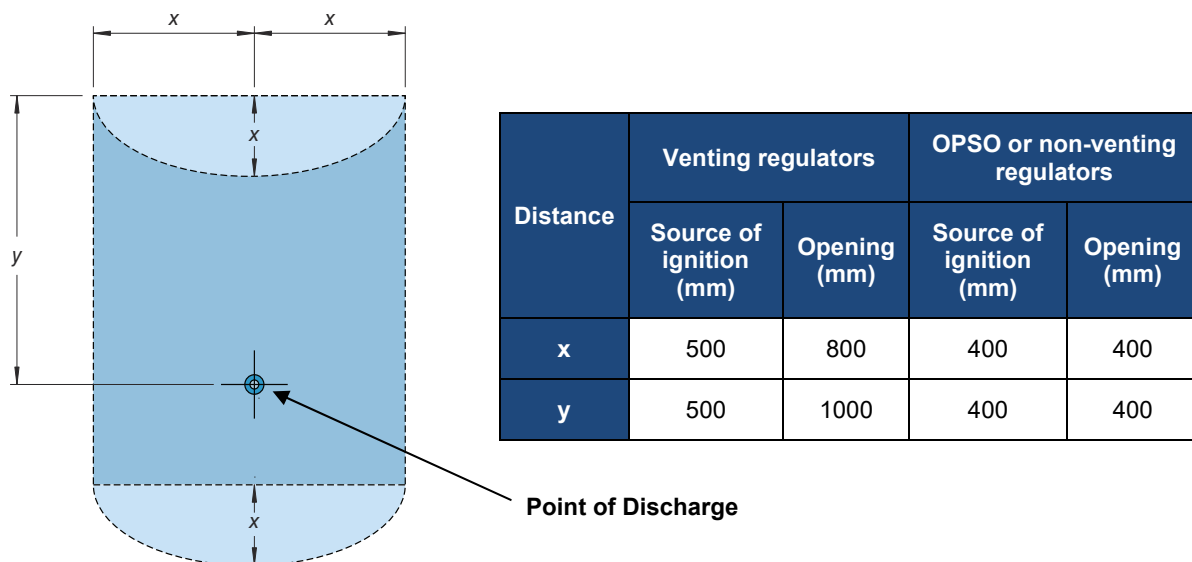

**Note:** For venting regulators the vent position is horizontal or downwards, if regulator vent discharges in an upwards direction,  $y$  shall be multiplied by 1.5.

**Figure 7: Basic metering equipment exclusion zones to openings and source of ignition**

## 6.8.2 EXCLUSION ZONES FOR MEDIUM PRESSURE BASIC METERING EQUIPMENT

For medium pressure **basic metering equipment** installed outside and fitted with a pressure relief valve, apply the clearances and exclusion zones in *Section 6.8.1* as well as the exclusion zones in *Section 6.9.3* for the relief vent terminal.

## 6.9 RELIEF VENT

---

### 6.9.1 GENERAL

All pressure relief valve vents must be vented outside the enclosure according to the requirements in *AS/NZS 4645.1 - Gas Distribution Networks (Network Management)*; this also applies to partial relief valves.

This may require penetrations through the external face of the building for vent line installation. The exclusion zones for the vent terminals shall be in accordance with the requirements in *Section 6.9.3 - Relief Vent Terminal Location*.

Relief vent line terminal should be positioned such that gas discharge can be detected (i.e., smelt or heard by the building owner, management staff or member of the public). The vent line terminal must be protected from rainwater and vermin ingress as indicated in Figure 8.

### 6.9.2 RELIEF VENT SIZING

Relief vent lines up to 30 metres in length shall be sized in accordance to *AS/NZS 4645.1 - Gas Distribution Networks (Network Management)*. For vent lines in excess of 30 metres length, the vent diameter shall be sized to limit maximum backpressure in the vent line to 10% of relief valve set pressure.

### 6.9.3 RELIEF VENT TERMINAL LOCATION

A relief vent terminal shall be located where gas discharge will dissipate without entering buildings or creating any hazard. The point of discharge shall:

- a) Be located so there is no **ignition source** or opening into a building within the exclusion zone shown in Figure 8;
- b) Be at least three (3) m from a mechanical air inlet unless calculations based on Figure 8 below give a greater distance;

In cases where there is any object (e.g. wall, ground, etc.) in the direction of discharge and within the exclusion zone of Figure 8, install a vent line to redirect the gas discharge so there is no **ignition source** or opening into a building within a sphere of radius L (of Figure 8) centred on the vent terminal discharge point.

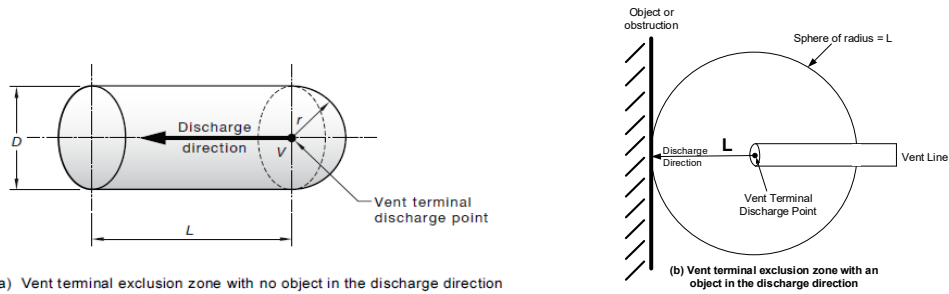

(a) Vent terminal exclusion zone with no object in the discharge direction

(b) Vent terminal exclusion zone with an object in the discharge direction

Vent terminal diameter (not shown)	Exclusion zone, m		
	$L$	$D$	$r$
Not exceeding 50 mm	1.5	1	0.5
Exceeding 50 mm	$1.5T$	$T$	$0.5T$

**Notes:**

1.  $T = \frac{\text{Vent terminal diameter (mm)}}{50}$
2. The exclusion zone shown in Figure 8 (a) and (b) depict a space consisting of a cylinder in the discharge direction and a hemisphere in the opposite direction of discharge from the vent terminal discharge point.

**Figure 8: Vent Terminal Exclusion Zone**

**6.9.4 RELIEF VENT TERMINAL DESIGN**

A relief vent terminal shall be designed as shown in Figure 9 and,

- a) The vent line will include a union near the device to be vented, unless the vent line can otherwise be readily removed; The mesh material shall be chemically compatible with the vent line material, e.g., for copper vent piping, brass mesh shall be used;
- b) Minimum mesh size shall be 2mm x 2mm aperture;
- c) Maximum mesh size shall be 3mm x 3mm aperture;
- d) Due to flow restriction generated by the mesh, the vent terminal diameter must be increased one size larger than the vent line diameter;
- e) Mesh shall be cut to match the elliptical shape of the vent terminal chamfer. Mesh may be attached to vent terminal using tack brazing (silver solder).

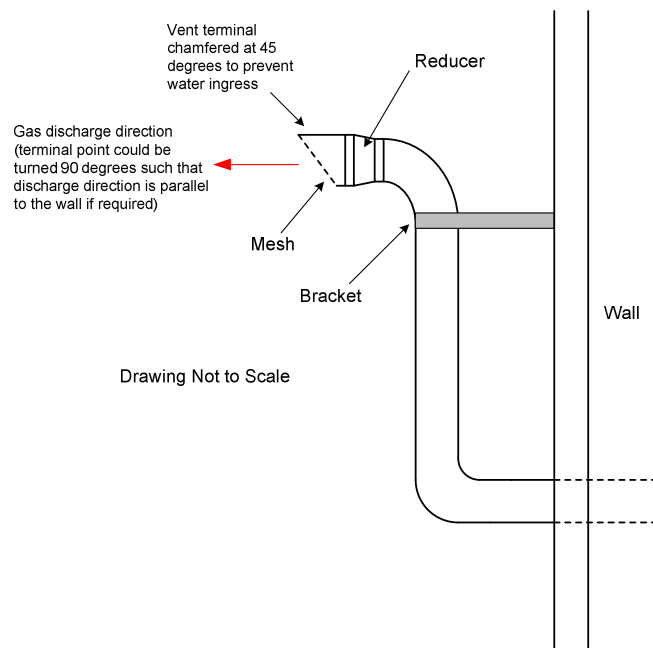

**Figure 9: Recommended Vent Terminal Geometry**

## 6.9.5 PROHIBITED MATERIALS FOR VENT PIPE

**Jemena** prohibits the use of composite and plastic vent pipes.

## 6.10 OUTLET METER PRESSURE FOR SIZING CONSUMER PIPING SYSTEM

---

Pressure loss between the inlet of the meter (metering pressure) and the outlet of the meter should not exceed the values shown in Table 4 below:

**Table 4: Allowable Pressure Loss Across Meters**

Inlet Meter Pressure (kPa)	Pressure drop across the meter (kPa)	Recommended Outlet Meter Pressure (kPa) to be used when sizing consumer piping system
1.38	0.125	1.255
2.75	0.25	2.5
5	0.5	4.5
35	0.5	34.5
100	0.5	99.5

## 6.11 METER IDENTIFICATION

---

Where two or more meters are installed in the same location, each meter must be identified by clear marking on the **meter kit** to indicate the building/premise/shop or part of the building/premise/shop supplied by the meter.

## 6.12 METER BY-PASS

---

If an uninterrupted supply of gas is essential **Jemena** must be notified at the time of requesting supply to enable **Jemena** to determine the suitability of a permanent meter by-pass. Meter by-passes are usually installed in the following conditions:

- (a) Continuously operated industrial or commercial processes e.g. galvanising kettles;
- (b) Public and large private hospitals;
- (c) Processes carried out regularly during late evening and early morning, e.g. **gas installation** bread baking; or
- (d) Air conditioning systems under continuous operation.

The authority to fit or operate a by-pass must be obtained from **Jemena** prior to use.

Meter by-pass valves are sealed in the closed position and must not be operated unless authorised by **Jemena**.

Meter bypass valves shall not be used for new connections or alterations/additions.

## 6.13 METER OPERATING PRESSURE

---

The setting of **basic metering equipment** operating pressures is the responsibility of **Jemena** and should not be adjusted by any other parties unless authorised by **Jemena**.

## 6.14 METER HANDLING

---

When transporting, storing, moving, installing or changing meters:

- (a) Handle with care to prevent damage, place carefully and do not drop;
- (b) Cap or seal their inlet and outlet connections from the atmosphere;
- (c) Keep in an upright position;
- (d) Keep clear of **ignition sources** if the meter has previously contained gas;
- (e) Prevent contamination by liquids or solids; and
- (f) Install in accordance with relevant **Jemena** installation instructions/drawings.

## 6.15 METER CHANGE / METER UPGRADE

---

When the gas flow requirements change and a premises requires a smaller or larger meter to be installed, the **licenced person** performing the work must:

- (a) Request application via gas portal (see *Part 1 Section 1.7 – Contact Details*);
- (b) Contact **Jemena's** authorised contractor for the new meter to be issued (see *Part 1 Section 1.7 – Contact Details*);
- (c) Install the new meter;
- (d) Provide a leak test certificate (and a certificate of compliance if the work is not performed for **Jemena**);
- (e) Attach an identification label to the old meter stating the address from which the meter was disconnected; and
- (f) Return the old meter to **Jemena** as per *Section 6.16 – Returning a Gas Meter* below.

## 6.16 RETURNING A GAS METER

---

Under the NSW Gas Supply Act, it is illegal to tamper with and/or remove a gas meter. A person must not alter or otherwise interfere with a meter that is connected to the **network** unless authorised to do so by **Jemena**.

A penalty may be imposed of up to \$22,000 (200 penalty units) in the case of a corporation and \$5,500 (50 penalty units) in any other case.

An application for a meter removal shall be made via the **gas retailer** responsible for the site. If no **gas retailer** is responsible for the site than an application can be made to Jemena via the Gas Portal (see *Part 1 Section 1.7 – Contact Details*). Charges will apply.

Once authorised, the **licenced person** may disconnect a meter for return to **Jemena**. The **licenced person** performing the work must, after disconnecting the meter:

- (a) Cap off the **consumer piping** system;
- (b) Cap off the **consumer service** pipe;
- (c) Cap off the meter inlet and outlet connection;
- (d) Read and record the final meter reading. This reading must be provided with the meter when it is returned to **Jemena**;

- (e) Attach an identification label stating the address from which the meter is being returned and the master meter number, if applicable;
- (f) Return the meter to **Jemena's** meter centre (14 Donald Street, Old Guildford NSW 2161) or **Jemena** depot (if outside the Sydney metro area) within two (2) business days of the disconnection occurring; and
- (g) Complete a "Home of Meter" notice.

## 6.17 PERMANENT DISCONNECTIONS

---

Permanent disconnections, also referred to as an abolishment, can only be performed by **Jemena** or a **Jemena** authorised representative. This work may involve isolating the **consumer service** either at the **property boundary** or at the point of connection on the **gas main**.

An application for an abolishment shall be made via the **gas retailer** responsible for the site. If no **gas retailer** is responsible for the site, then an application can be made to **Jemena** via the Gas Portal (see *Part 1 Section 1.7 – Contact Details*). Charges will apply.

## 6.18 SAFETY SHUT OFF SYSTEMS

---

Automatic fast acting safety shut off valves and gas appliances installed close to the outlet of **basic metering equipment** can cause the over pressure protection devices fitted to **basic metering equipment** to activate prematurely. This may lead to unnecessary shutdown of supply or lifting of relief valves.

To limit the potential for this to occur, avoid installing fast acting safety shut off valves and gas appliances immediately on the outlet of the **basic metering equipment**.



## 7 APPENDICES

### 7.1 TRAFFIC PROTECTION BARRIERS

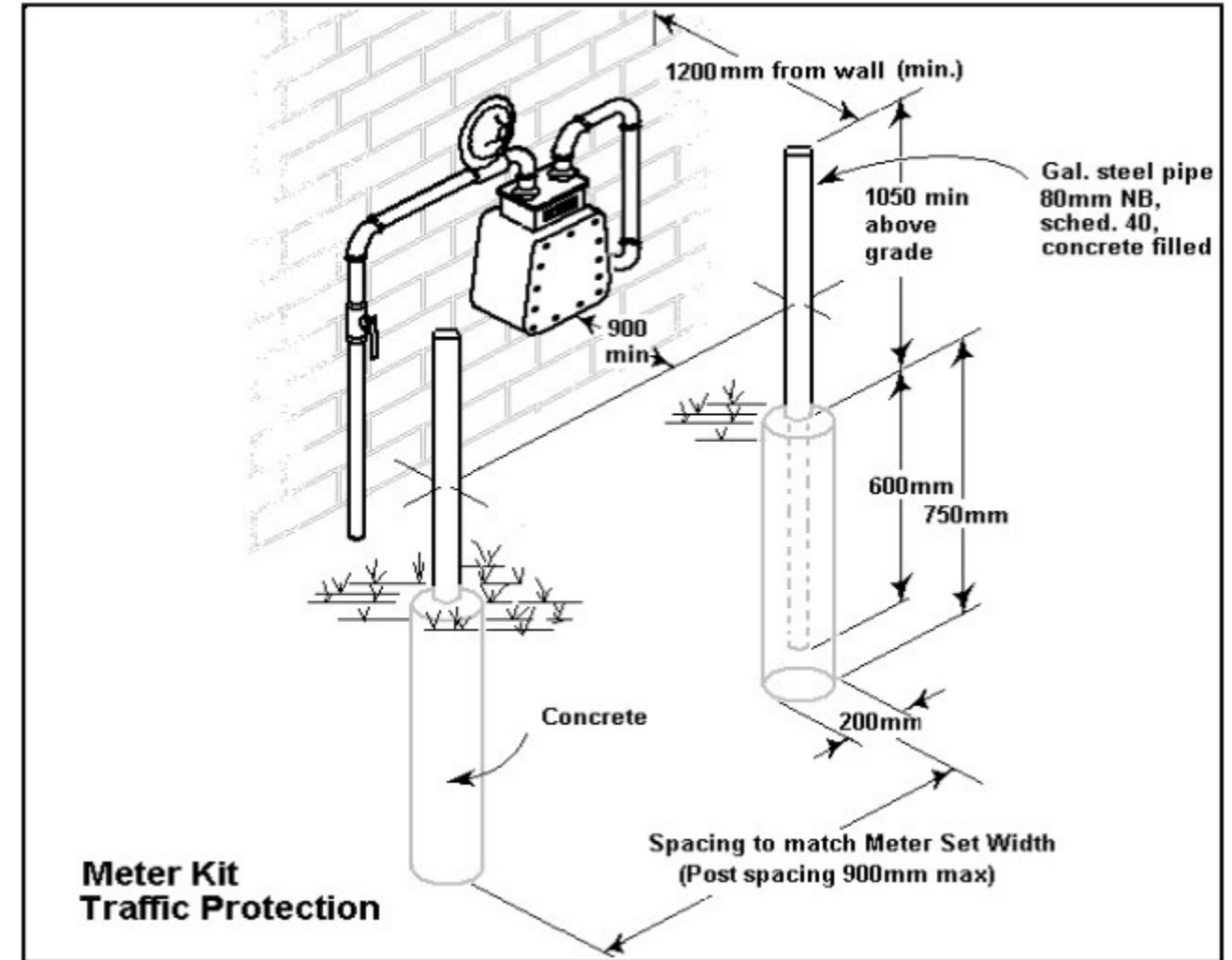
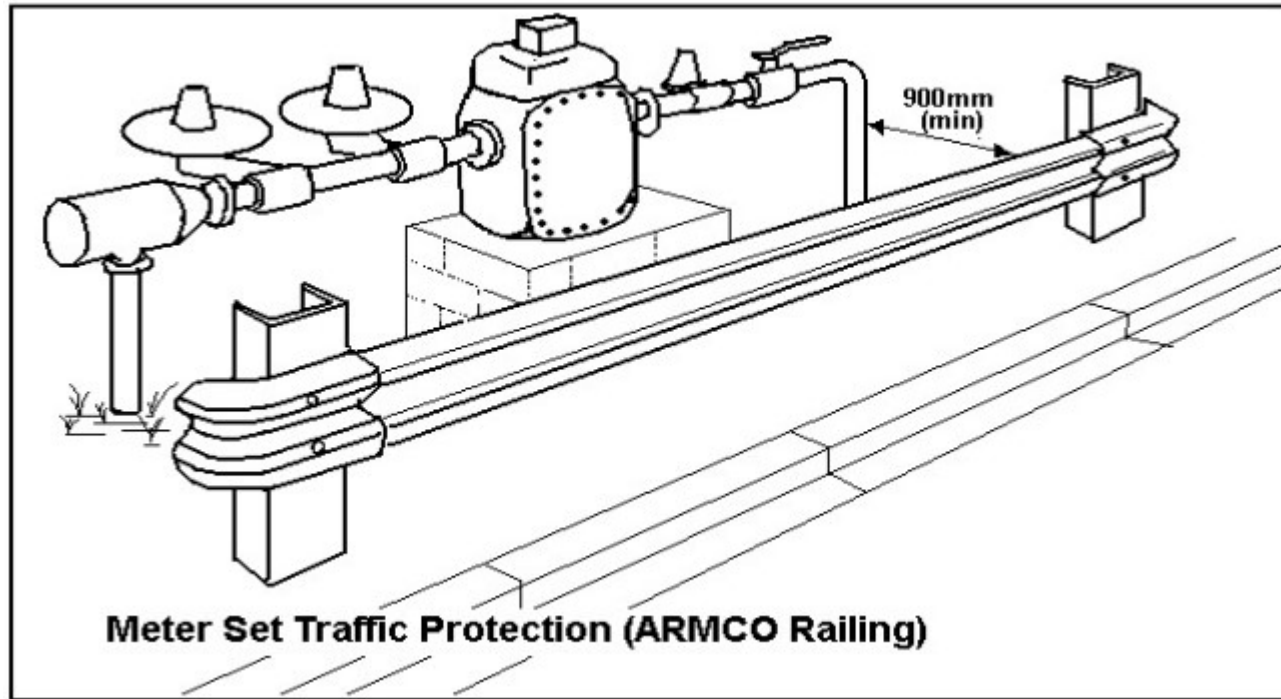

7.2 CLEARANCE FROM OTHER UTILITIES

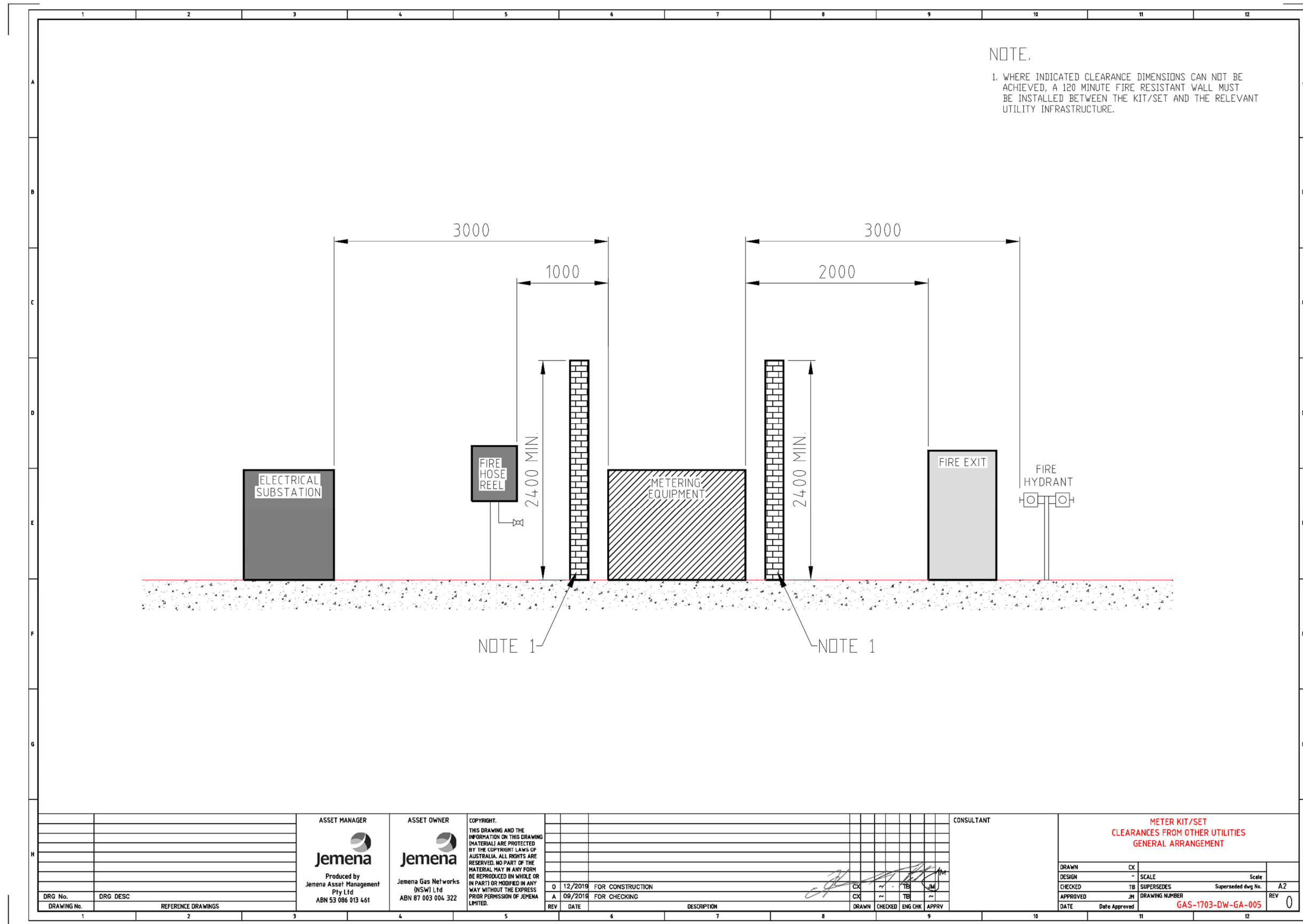

ASSET MANAGER <b>Jemena</b> Produced by Jemena Asset Management Pty Ltd ABN 53 086 013 461		ASSET OWNER <b>Jemena</b> Jemena Gas Networks (NSW) Ltd ABN 87 003 004 322		COPYRIGHT. THIS DRAWING AND THE INFORMATION ON THIS DRAWING (MATERIAL) ARE PROTECTED BY THE COPYRIGHT LAWS OF AUSTRALIA. ALL RIGHTS ARE RESERVED. NO PART OF THE MATERIAL MAY IN ANY FORM BE REPRODUCED IN WHOLE OR IN PART OR MODIFIED IN ANY WAY WITHOUT THE EXPRESS PRIOR PERMISSION OF JEMENA LIMITED.		CONSULTANT		METER KIT/SET CLEARANCES FROM OTHER UTILITIES GENERAL ARRANGEMENT						
DRG No.	DRG DESC	REFERENCE DRAWINGS		REV	DATE	DESCRIPTION	DRAWN	CHECKED	ENG CHK	APPRV	DATE	Date Approved	DRAWING NUMBER <b>GAS-1703-DW-GA-005</b>	REV 0



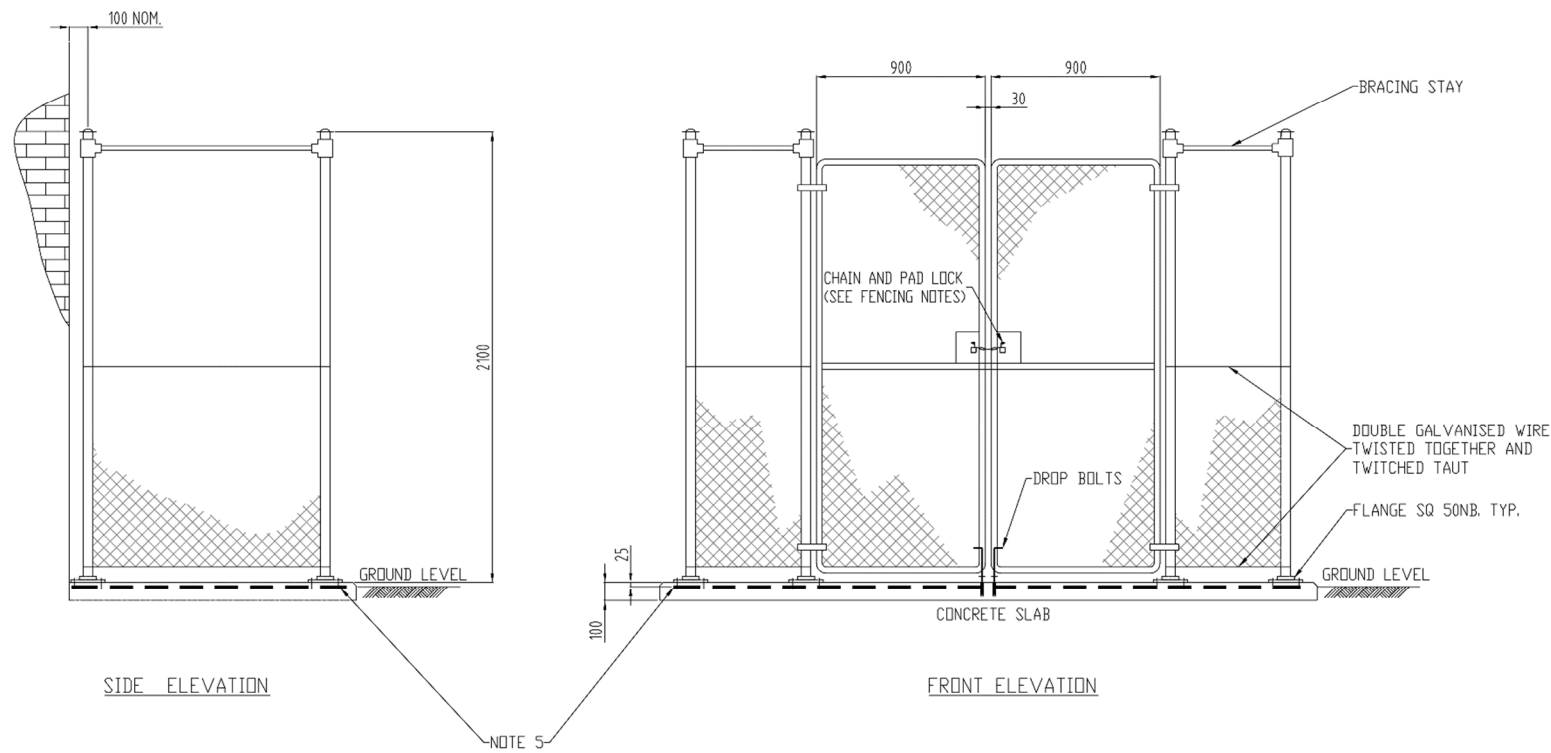
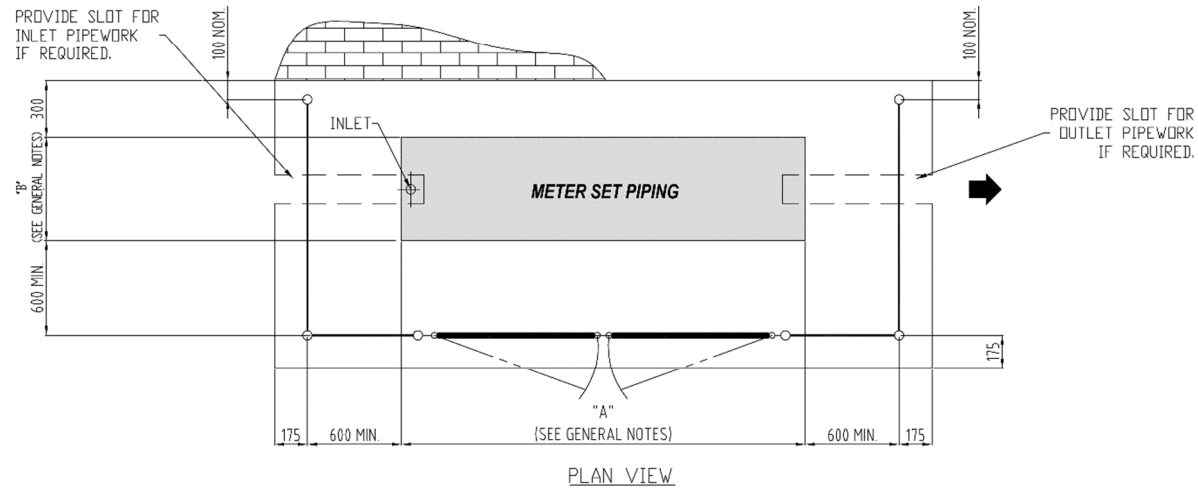

**GENERAL NOTES**

1. THIS DRAWING TO BE USED IN CONJUNCTION WITH CORRESPONDING GENERAL ARRANGEMENT OF SET TO BE INSTALLED.
2. DIMENSIONS 'A' & 'B' ARE DEPENDENT ON MODEL OF SET TO BE INSTALLED. REFER SPECIFIC SITE LAYOUT FOR DIMENSIONS.
3. PERMANENT SAFETY BARRIER MUST BE ERECTED BETWEEN SET AND ANY ADJACENT VEHICULAR TRAFFIC THOROUGHFARE. SAFETY BARRIER NOT TO IMPEDE OPENING OF ENCLOSURE GATES.
4. NO OBSTRUCTION TO BE PLACED WITHIN 900mm OF METER ENCLOSURE GATES.
5. SL62 REINFORCEMENT MESH PLACED ABOUT 25mm FROM TOP OF THE CONCRETE SLAB.

**FENCING NOTES**

1. CYCLONE CHAINWIRE FENCING TO BE USED OR APPROVED EQUIVALENT. CHAINWIRE TYPE HEAVY DUTY GALVANISED 50 MESH x 2.5mm THICK.
2. ALL FENCE UPSTANDS TO BE HEAVY GALVANISED POSTS x 50NB. FENCEPOST UPSTANDS TO BE SECURED WITH BASE PLATE TYPE PESO SQUARE.
3. BASE PLATE TO BE ANCHORED INTO CONCRETE WITH 'RAMSET' GALVANISED TYPE TRUBOLT, 4 PER POST.
4. PROVIDE CYCLONE GALVANISED DROP BOLT AND HOLES IN CONCRETE TO HOLD GATES IN CLOSE POSITION.
5. PROVIDE APPROPRIATE GALVANISED CHAIN FOR LOCKING SYSTEM. JEMENA WILL PROVIDE DISTRIBUTION PADLOCK ON SET COMMISSIONING.

**CONCRETE NOTES**

1. ALL CONCRETE WORK, WORKMANSHIP AND MATERIAL SHALL BE IN ACCORDANCE WITH AS3600 SAA CONCRETE STRUCTURES CODE.
2. DIMENSIONS SHALL NOT BE OBTAINED BY SCALING THE STRUCTURAL DRAWINGS.
3. UNDERSIDE AND THE SIDES OF THE SLAB ARE TO BE SEPARATED FROM THE UNDERLYING MATERIAL BY AN 200 MICRONS THICK IMPERVIUS MEMBRANE.
4. MEMBRANE TO BE IN ACCORDANCE WITH AS1303, AND HAVE A MINIMUM LAP OF 225. JOINTS TO BE SECURELY SEAL TAPED.
5. REINFORCEMENT IS SHOWN DIAGRAMMATICALLY, AND IS NOT NECESSARILY SHOWN IN TRUE POSITION.
6. REINFORCEMENT SHALL BE ACCURATELY AND SECURELY POSITIONED. CHAIRS TO BE SPACED AT APPROX. 1000 CENTRES.
7. ALL CONCRETE GRADE AND CLASS SHALL BE IN ACCORDANCE WITH TO FOLLOWING:  
 CONCRETE CLASS-----N32 TO AS3600.  
 MINIMUM CEMENT CONTENT-----350 kg / cu-m  
 MAXIMUM WATER / CEMENT RATIO 0.50  
 COMPRESSIVE STRENGTH-----32MPa  
 MAXIMUM AGGREGATE SIZE-----20mm  
 MAXIMUM SLUMP-----75mm.
8. ALL CONCRETE SHALL BE COMPACTED USING A APPROVED MECHANICAL VIBRATOR.
9. CONCRETE SHALL BE COVERED WITHIN 2 HOURS OF FINISHING WITH WELL SECURED SHEET POLYTHENE FOR A MINIMUM OF 7 DAYS.

**SIGNAGE NOTES**

1. SIGNAGE SHALL BE PROVIDED AS FOLLOWS:  
 NO SMOKING  
 NO ENTRY AUTHORISED PERSONS ONLY  
 DANGER FLAMMABLE GAS  
 IN CASE OF EMERGENCY CALL 131909

**FOR CONSTRUCTION**

ASSET MANAGER		ASSET OWNER		CONSULTANT		METER SET FENCING ENCLOSURE DETAILS POSITIONED AGAINST WALL	
 Produced by Jemena Asset Management (6) Pty Ltd ABN 52 104 352 650		 Jemena Gas Networks (NSW) Ltd ABN 87 003 004 322		4 08/2019 REMOVED SIDE GATE, ADJUSTED CLEARANCE DIMENSIONS, REINFORCEMENT POSITION AND NOTES UPDATE 3 01/10 REVISION UPDATES 2 07/09 MODIFICATION FOR GENERIC DESIGN 1 5/11/08 FOR CONSTRUCTION A 5/11/08 FOR CHECKING		DRAWN CX DESIGN TB CHECKED TB APPROVED JM DATE Date Approved	
DRG No.	DRG DESC	REFERENCE DRAWINGS	ABN 52 104 352 650	322	REVISION	DATE	DESCRIPTION
1							
2							
3							
4							
5							
6							
7							
8							
9							
10							
11							
12							



7.4 TYPE 2 ENCLOSURE REQUIREMENTS

